

**Kawasaki Robot
F Series (C0**)**

**Installation and
Connection Manual**

= Arm =

Robot

Kawasaki Heavy Industries, Ltd.

PREFACE

This manual describes installation and connection procedures for Kawasaki Robot F Series (C0**).

Read and understand the contents of this and safety manuals thoroughly and strictly observe all rules for safety before proceeding with any operation. Kawasaki cannot take any responsibility for any accidents and/or damages caused by operations that are based on only the limited part of this manual.

This manual describes only the installation and connection of the Robot Arm (C0**). Please refer to the following manual for installation and connection of Controller and for Arc-welding Robots.

“Installation and Connection” for controller

“Installation and Connection” for arc welding

— This Manual describes on the following Robot Arms —

FS06N (C0**), FS06L (C0**), FA06N (C0**), FA06E (C0**), FC06N (C0**), FC06L (C0**),
FS10C (C0**), FS10N (C0**), FS10E (C0**), FS10L (C0**), FS10X (C0**), FA10N (C0**),
FA10L (C0**), FC10N (C0**), FC10L (C0**),
FS20C (C0**), FS20N (C0**), FS20X (C0**), FA20N (C0**), FC20N (C0**),
FS30N (C0**), FS30L (C0**), FA30L (C0**), FC30N (C0**), FC30L (C0**),
FS45C (C0**), FS45N (C0**), FC45N (C0**),
FD50N (C0**),
FS60L (C0**), FC60L (C0**)

-
1. This manual does not constitute a guarantee of the systems in which the robot is utilized. Accordingly, Kawasaki is not responsible for any accidents, damages, and/or problems relating to industrial property rights as a result of using the system.
 2. It is recommended that all personnel assigned for activation of operation, teaching, maintenance or inspection of the robot attend the necessary education/training course(s) prepared by Kawasaki, before assuming their responsibilities.
 3. Kawasaki reserves the right to change, revise, or update this manual without prior notice.
 4. This manual may not, in whole or in part, be reprinted or copied without the prior written consent of Kawasaki.
 5. Store this manual with care and keep it available for use at any time. If the robot is reinstalled or moved to a different site or sold off to a different user, attach this manual to the robot without fail. In the event the manual is lost or damaged severely, contact Kawasaki.
-

All rights reserved. Copyright © 2006 Kawasaki Heavy Industries Ltd.

SAFETY

The items that require special attention in this manual are designated with the following symbols.

Ensure proper and safe operation of the robot and prevent physical injury or property damages by complying with the safety matters given in the boxes with these symbols.

 **DANGER**

Failure to comply with indicated matters can result in imminent injury or death.

 **WARNING**

Failure to comply with indicated matters may possibly lead to injury or death.

 **CAUTION**

Failure to comply with indicated matters may lead to physical injury and/or mechanical damage.

[NOTE]

Denotes precautions regarding robot specification, handling, teaching, operation, and maintenance.

 **WARNING**

- 1. The accuracy and effectiveness of the diagrams, procedures, and detail explanations given in this manual cannot be confirmed with absolute certainty. Accordingly, it is necessary to give one's fullest attention when using this manual to perform any work.**
- 2. Safety related contents described in this manual apply to each individual work and not to all robot work. In order to perform every work in safety, read and fully understand the safety manual, all pertinent laws, regulations and related materials as well as all the safety explanation described in each chapter, and prepare safety measures suitable for actual work.**

CONTENTS

Preface	1
Safety	2
1.0 Precautions	4
1.1 Precautions to be Taken during Transportation, Installation and Storage.....	4
1.2 Installing Environment of Robot Arm.....	5
1.3 Warning Label	6
2.0 Work Flow at Arm Installation and Connection.....	7
3.0 Motion Range & Specifications of Robot	8
3.1 Determination of Safety Fence Location based on Motion Range.....	8
3.2 Motion Range & Specifications of Robot	9
4.0 Robot Transportation Method – Wire Sling	40
5.0 Installing Dimensions of Base Section	41
6.0 Dimensions of Robot Stand	42
7.0 Installation Method	43
7.1 When Installing the Base Directly on the Floor	43
7.2 When Installing the Robot Stand on the Floor	44
7.3 When the Robot Base Plate is Installed on the Floor	45
8.0 Mounting of Tools	46
8.1 Dimensions of Wrist End.....	46
8.2 Specification of Fixing Bolt.....	46
8.3 Load Capacity	48
9.0 Connection of Air System.....	53
9.1 Air Piping Arrangement.....	53
9.2 Air Supply to the Robot Arm.....	58
9.3 Connection of Air Outlet Port in the Wrist Section with the Hand.....	60

1.0 PRECAUTIONS

1.1 PRECAUTIONS TO BE TAKEN DURING TRANSPORTATION, INSTALLATION AND STORAGE

When transporting the Kawasaki Robot to its installation site, strictly observe the following cautions.



WARNING

1. When the robot arm is to be transported by using a crane or forklift, never support the robot arm manually.
2. During transportation, never climb on the robot arm or stay under the hoisted robot arm.
3. Prior to installation, turn OFF the main power switch on the controller and the external power switch for shutting down power supply to the controller. Display signs indicating clearly “Inspection and Maintenance in Progress”, and lockout/tagout the external power switch to prevent personnel from accidentally turning ON the power.
4. Prior to driving robot, ensure safety by first confirming no abnormality is observed in installing condition, etc., and then turn ON motor power to set robot to the desired posture. Be careful to not be caught by/between any moving parts due to careless approach to robot and peripheral equipment. After setting robot arm to the specified pose, turn OFF the main power switch and the external power switch again as mentioned above. Display signs indicating clearly “Inspection and Maintenance in Progress”, and lockout/tagout the external power switch before starting inspection and maintenance.



CAUTION

1. Since the robot body unit is composed of precision parts, be careful not to apply excessive shocks or vibrations during transportation.
2. Prior to installation, remove all obstacles so the installation is carried out smoothly and safely. Clear a passage to the installation area for transportation of the robot arm using a crane or forklift.
3. During transportation and storage,
 - (1) Keep the ambient temperature within the range of $-10^{\circ}\text{C} \sim 60^{\circ}\text{C}$,
 - (2) Keep the relative humidity within the range of 35 % ~ 85 % RH without dew condensation,
 - (3) Keep free from excessively strong vibration.

1.2 INSTALLING ENVIRONMENT OF ROBOT ARM

The robot arm must be installed in a place that satisfies all the following environmental conditions:

1. When robot is installed on the floor, the level must be within $\pm 5^\circ$.
2. Be sure that the floor/stand has sufficient rigidity.
3. Secure a leveled place to prevent undue force application on the install position.
4. Keep the ambient temperature during operation within the range of $0^\circ\text{C} \sim 45^\circ\text{C}$.
(Deviation or overload error may occur due to high viscosity of grease/oil when starting operation at low temperatures. In this case, warm-up robot at low speed before regular operation.)
5. Keep the relative humidity during operation within the range of 35%~85%RH without dew condensation.
6. The robot installing place should be free from dust, dirt, smoke, water, and other foreign matters.
7. The robot installing place should be free from flammable or corrosive liquid or gas.
8. The robot installing place should be free from excessively strong vibration.
9. The robot installing place should be free from electric noise interference.
10. The robot installing place should be sufficiently larger than the motion range of robot arm.
 - (1) Safety fence must be larger than the maximum movement of fully equipped robot arm (with hands and guns) so it does not interfere with the surrounding objects.
 - (2) An entrance gate with a safety plug should be provided to the safety fence.
 - (3) About details of the safety fence, observe the requirements which are established in each region. (e.g. EN953, EN294, EN811, EN1088, ISO13852, ISO13854, and ISO/NP14120)

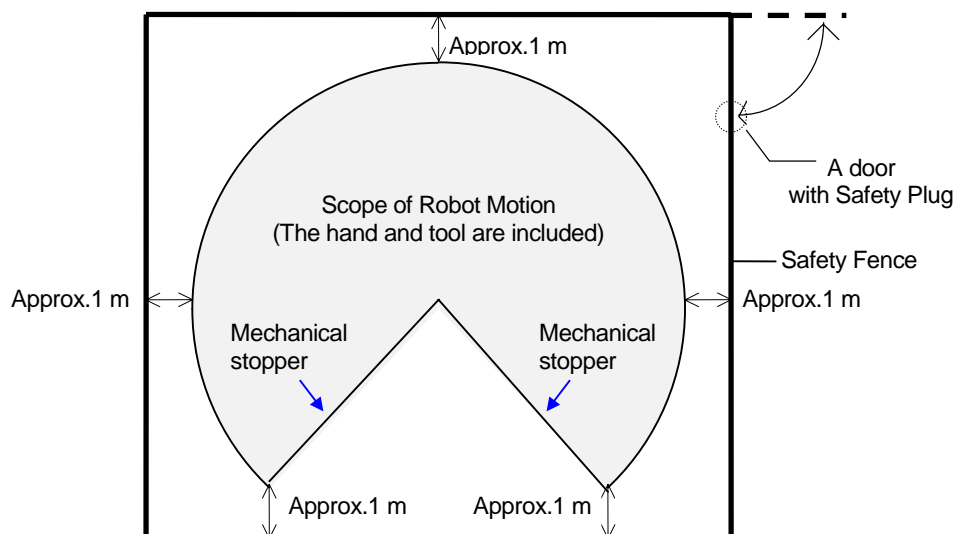

1.3 WARNING LABEL

 **WARNING**

Pay attention to the warning labels listed in the drawings below. (Though no warning labels are attached on FC series robots, pay attention to the same places.)

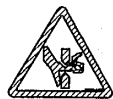
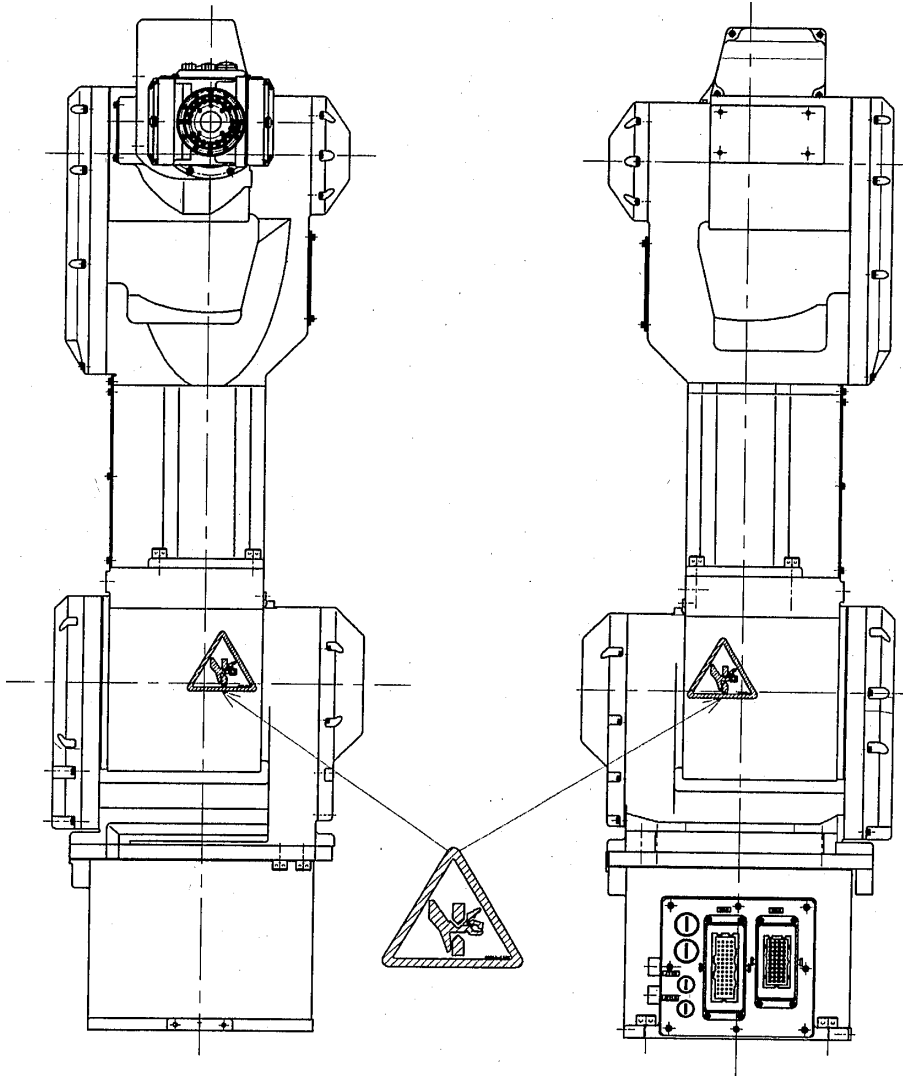

: Warning label for pinching/crushing

2.0 WORK FLOW AT ARM INSTALLATION AND CONNECTION

This workflow describes only the robot arm section. For the controller, refer to “Installation and Connection”.

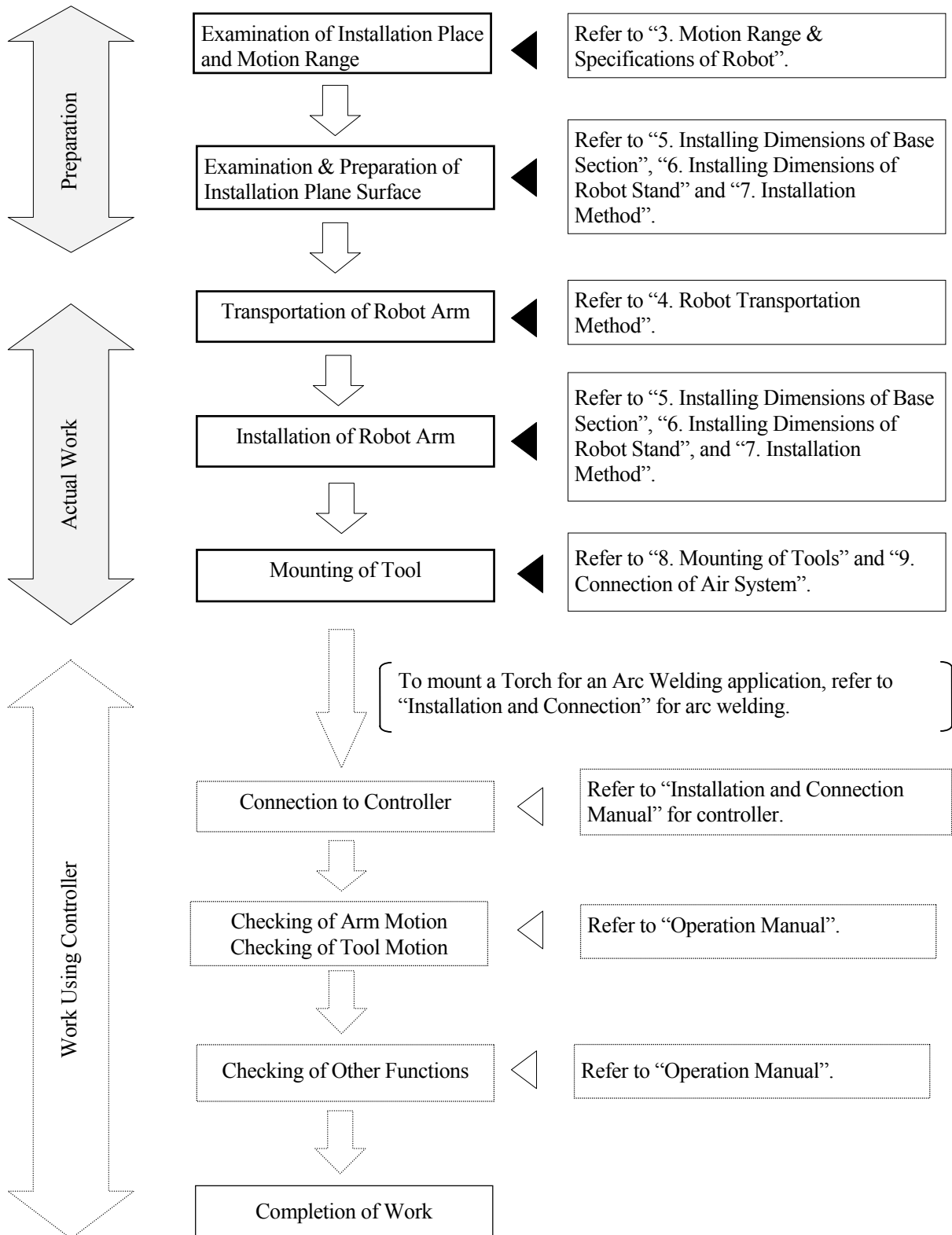

3.0 MOTION RANGE & SPECIFICATIONS OF ROBOT

3.1 DETERMINATION OF SAFETY FENCE LOCATION BASED ON MOTION RANGE

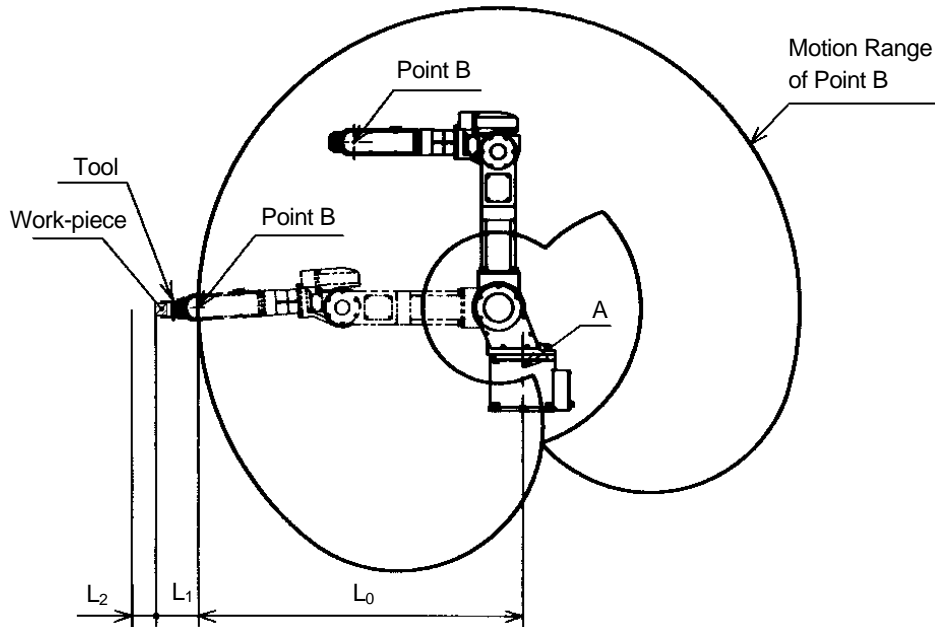

The motion range of the Robot is represented by the maximum area that can be covered by Point B in the figure above. Therefore, referring to the figure, the safety fence dimensions should be set up as follows: $L_0 + L_1 + L_2$. That is; from the center of arm (Point A shown above) to the Length of L_0 + Sum of the Length up to the max. dimensions allowed for Wrist flange, Tool, Hand and Work-piece : L_1 and L_2 . For the Length of L_0 , refer to the drawings for 3.2 Motion Range & Specifications of Robot.

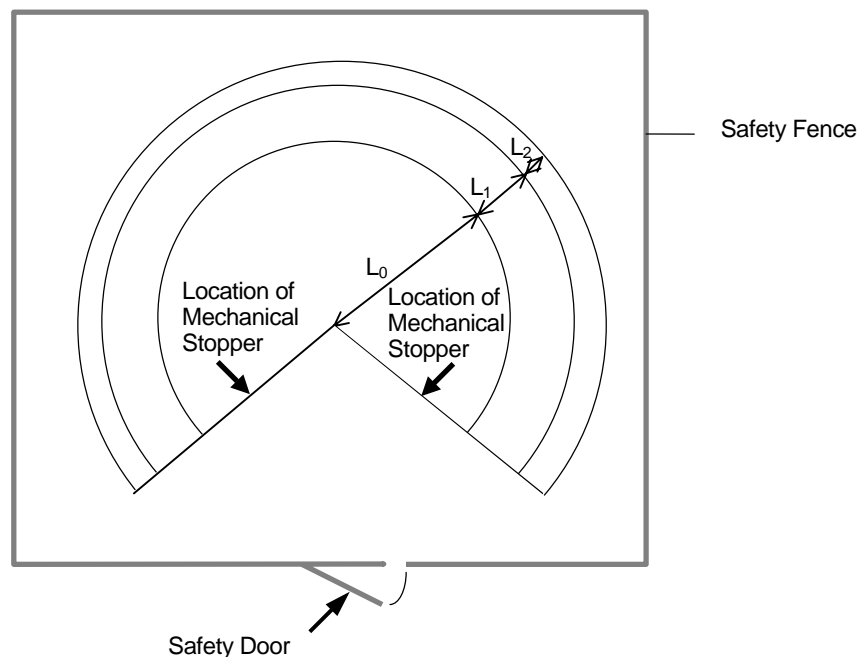

3.2 MOTION RANGE & SPECIFICATIONS OF ROBOT

FS06N

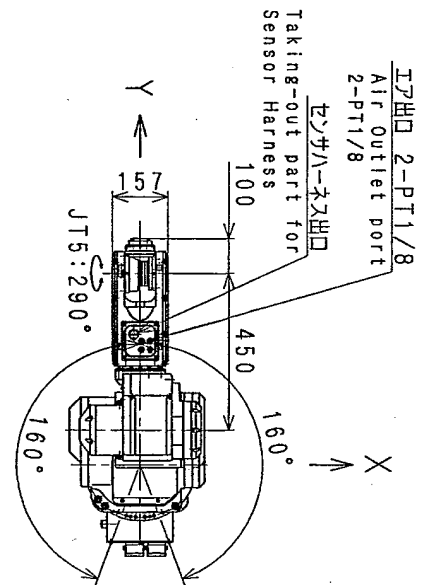
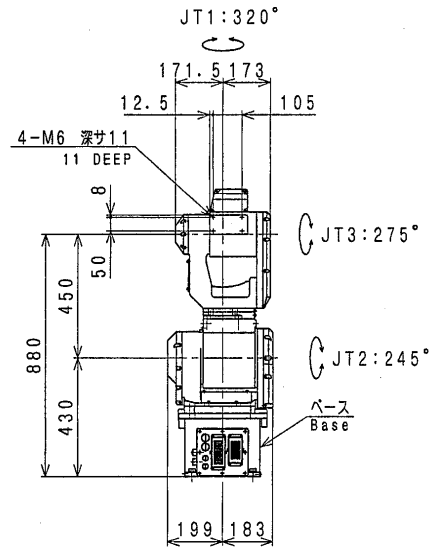
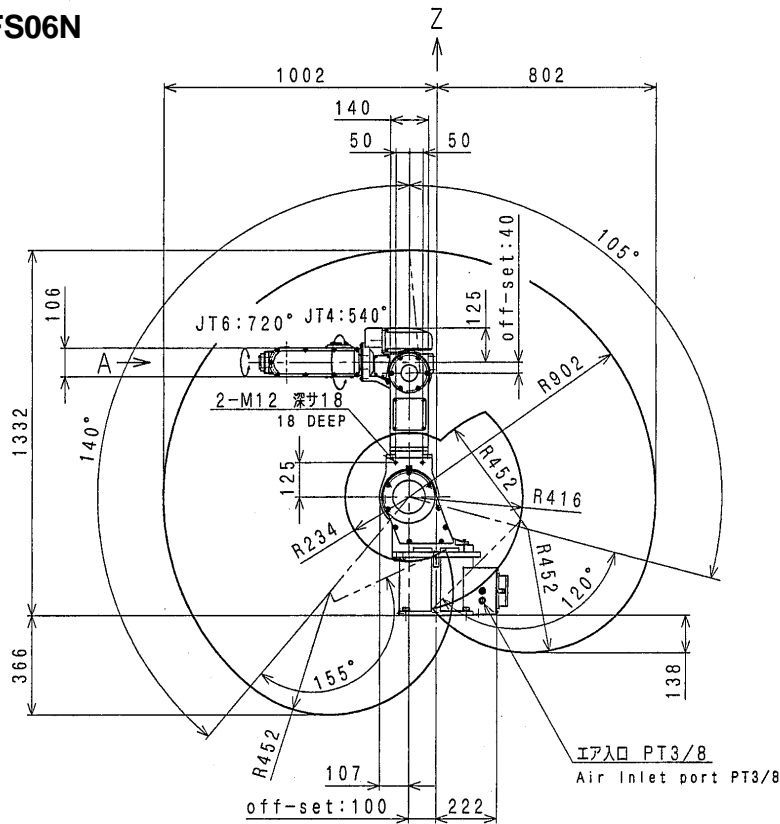

Type	Articulated Robot		
Degree of Freedom	6		
Motion Range and Maximum Speed	JT	Motion Range	Max. Speed
	1	±160°	240 %/s
	2	-105° to +140°	200 %/s
	3	-155° to +120°	250 %/s
	4	±270°	430 %/s
	5	±145°	430 %/s
6	±360°	720 %/s	
Max. Payload	6 kg		
Wrist Load Capacity	JT	Torque	Moment of Inertia
	4	12.0 N·m	0.24 kg·m ²
	5	12.0 N·m	0.24 kg·m ²
	6	6.0 N·m	0.07 kg·m ²
Repeatability	±0.05 mm		
Mass	Approx. 165 kg		
Acoustic noise	< 70 db (A)*		

*measured condition

- installed on the plate rigidly fixed on the floor
- 2300 mm away from JT1 center

The noise level depends on the conditions.

FS06L

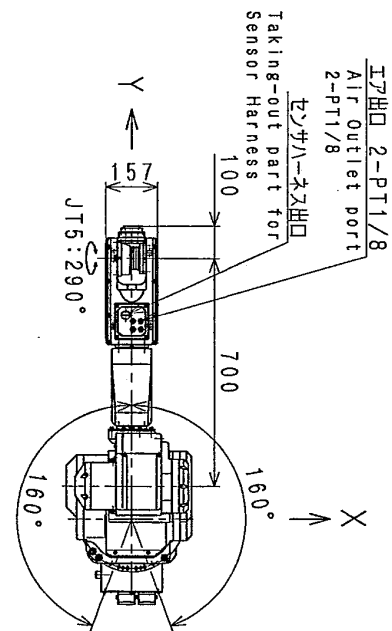
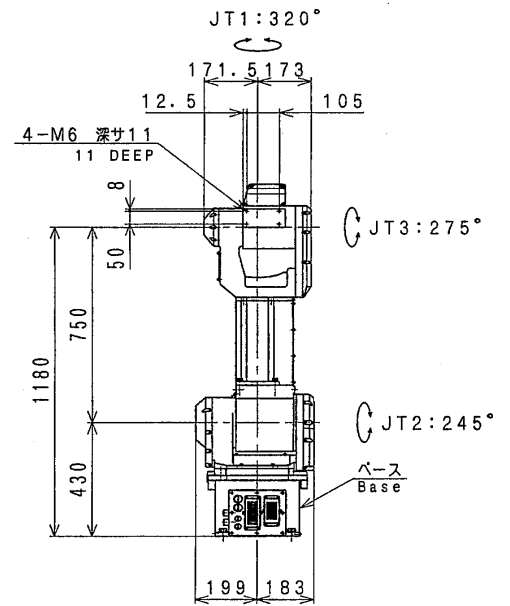
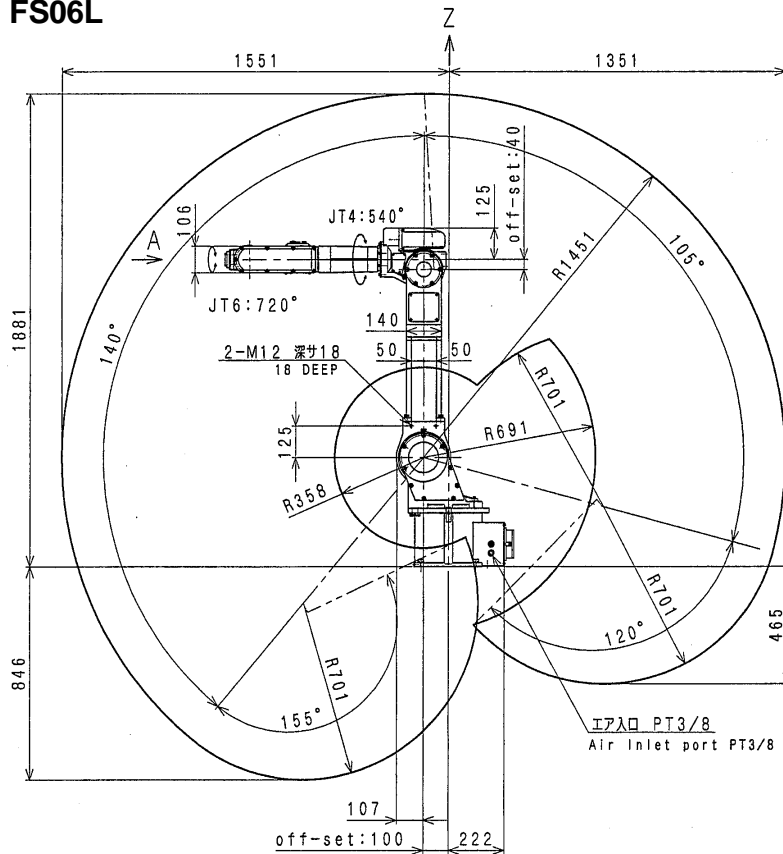

Type	Articulated Robot		
Degree of Freedom	6		
Motion Range and Maximum Speed	JT	Motion Range	Max. Speed
	1	±160°	200 °/s
	2	-105° to +140°	140 °/s
	3	-155° to +120°	200 °/s
	4	±270°	360 °/s
	5	±145°	360 °/s
6	±360°	600 °/s	
Max. Payload	6 kg		
Wrist Load Capacity	JT	Torque	Moment of Inertia
	4	12.0 N·m	0.24 kg·m ²
	5	12.0 N·m	0.24 kg·m ²
6	6.0 N·m	0.07 kg·m ²	
Repeatability	±0.1 mm		
Mass	Approx. 170 kg		
Acoustic noise	< 70 db (A)*		

*measured condition

- installed on the plate rigidly fixed on the floor
- 2900 mm away from JT1 center

The noise level depends on the conditions.

FS10C

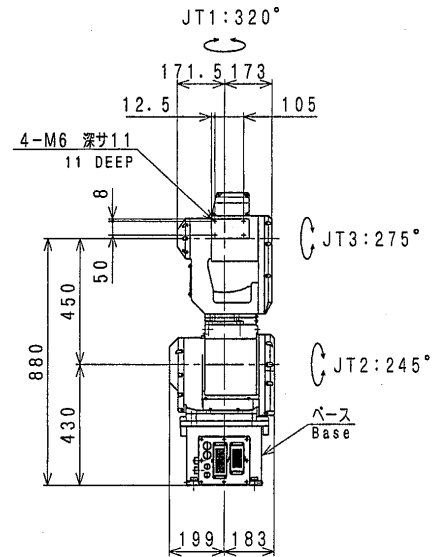
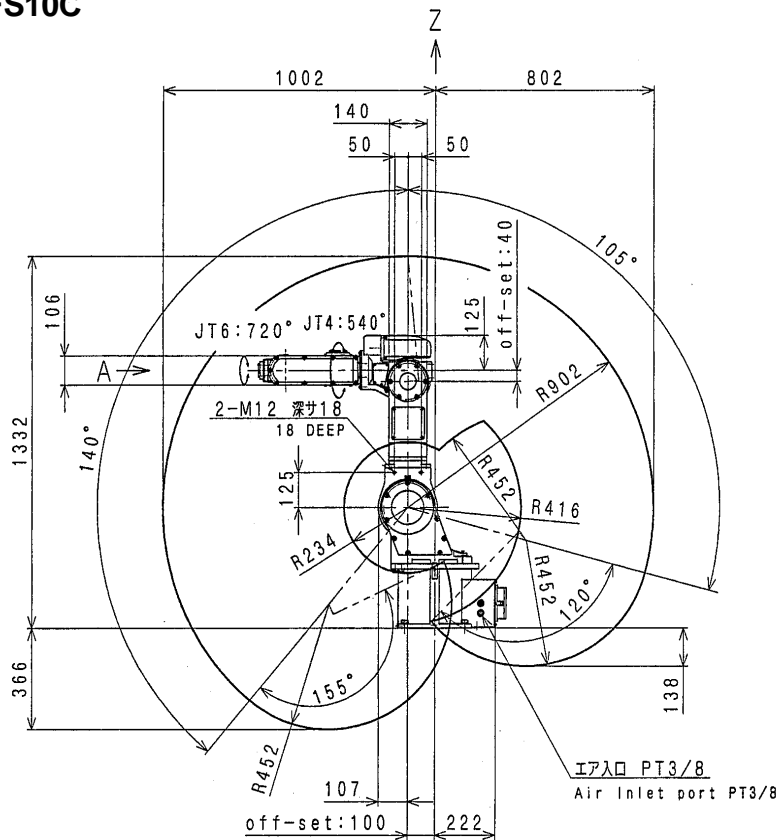

Type	Articulated Robot		
Degree of Freedom	6		
Motion Range and Maximum Speed	JT	Motion Range	Max. Speed
	1	±160°	200 °/s
	2	-105° to +140°	140 °/s
	3	-155° to +120°	200 °/s
	4	±270°	360 °/s
	5	±145°	360 °/s
6	±360°	600 °/s	
Max. Payload	10 kg		
Wrist Load Capacity	JT	Torque	Moment of Inertia
	4	21.5 N·m	0.63 kg·m ²
	5	21.5 N·m	0.63 kg·m ²
6	9.8 N·m	0.15 kg·m ²	
Repeatability	±0.05 mm		
Mass	Approx. 165 kg		
Acoustic noise	< 70 db (A)*		

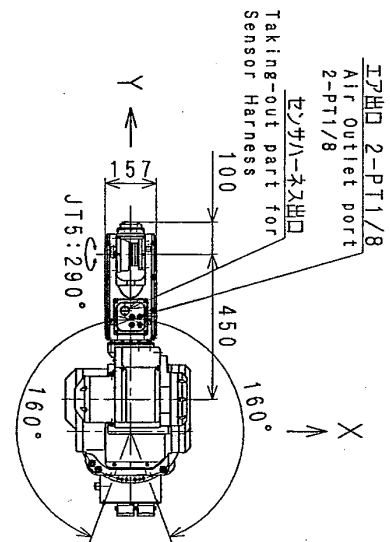

*measured condition
 • installed on the plate rigidly fixed on the floor
 • 2300 mm away from JT1 center

The noise level depends on the conditions.

FS10N

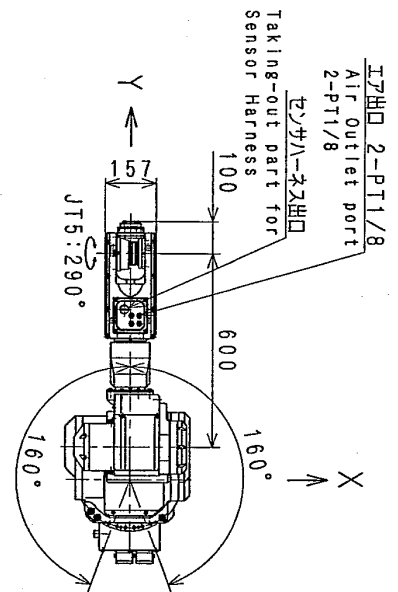
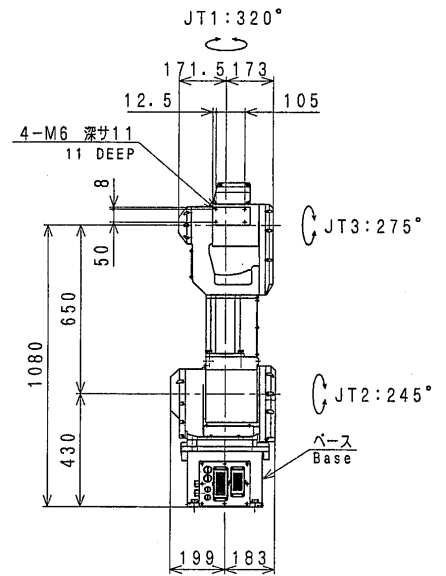
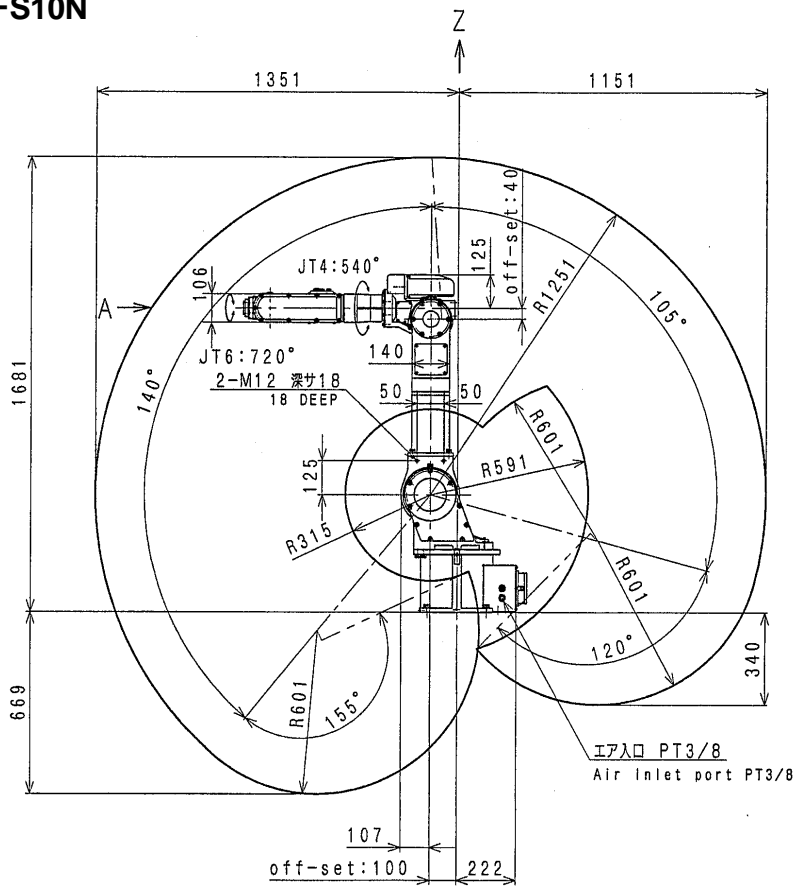

Type	Articulated Robot		
Degree of Freedom	6		
Motion Range and Maximum Speed	JT	Motion Range	Max. Speed
	1	±160°	200 °/s
	2	-105° to +140°	140 °/s
	3	-155° to +120°	200 °/s
	4	±270°	360 °/s
	5	±145°	360 °/s
Max. Payload	10 kg		
Wrist Load Capacity	JT	Torque	Moment of Inertia
	4	21.5 N·m	0.63 kg·m ²
	5	21.5 N·m	0.63 kg·m ²
6	9.8 N·m	0.15 kg·m ²	
Repeatability	±0.1 mm		
Mass	Approx. 170 kg		
Acoustic noise	< 70 db (A)*		

*measured condition
 • installed on the plate rigidly fixed on the floor
 • 2700 mm away from JT1 center

{ The noise level depends on the conditions. }

FS10E

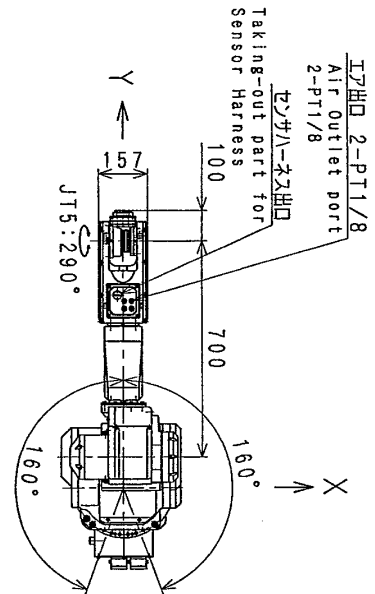
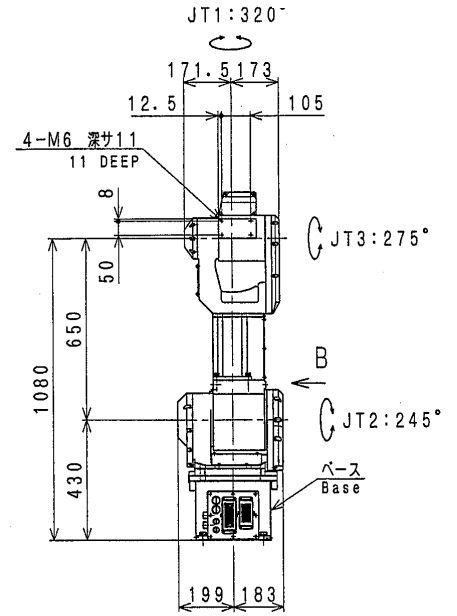
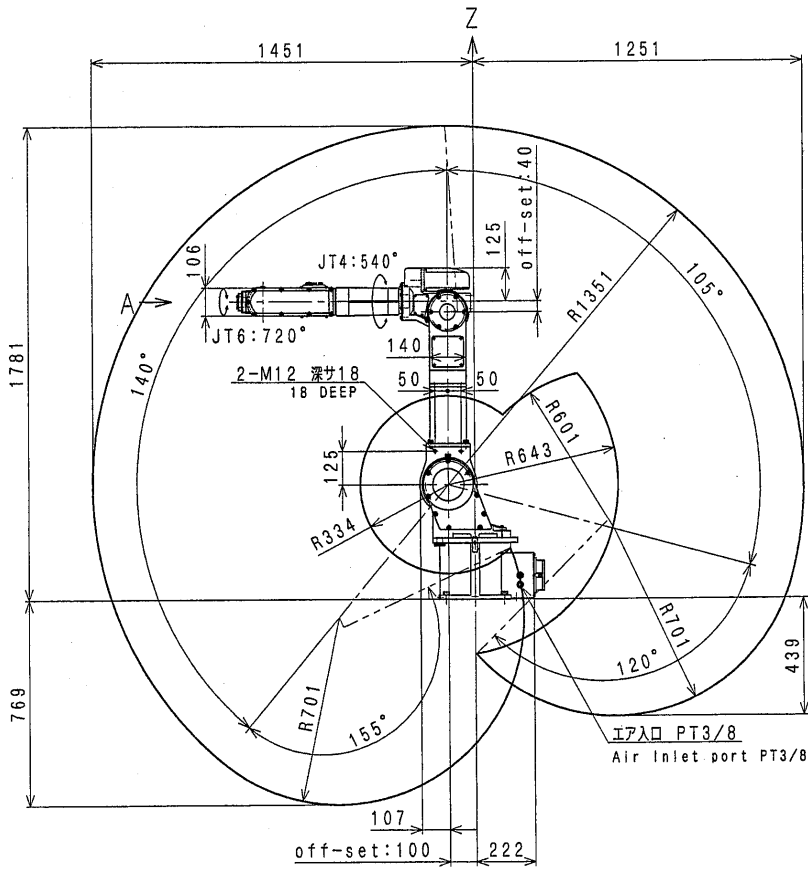

Type	Articulated Robot		
Degree of Freedom	6		
Motion Range and Maximum Speed	JT	Motion Range	Max. Speed
	1	±160°	200 °/s
	2	-105° to +140°	140 °/s
	3	-155° to +120°	200 °/s
	4	±270°	360 °/s
	5	±145°	360 °/s
6	±360°	600 °/s	
Max. Payload	10 kg		
Wrist Load Capacity	JT	Torque	Moment of Inertia
	4	21.5 N·m	0.63 kg·m ²
	5	21.5 N·m	0.63 kg·m ²
6	9.8 N·m	0.15 kg·m ²	
Repeatability	±0.1 mm		
Mass	Approx. 170 kg		
Acoustic noise	< 70 db (A)*		

*measured condition

- installed on the plate rigidly fixed on the floor
- 2800 mm away from JT1 center

The noise level depends on the conditions.

FS10L

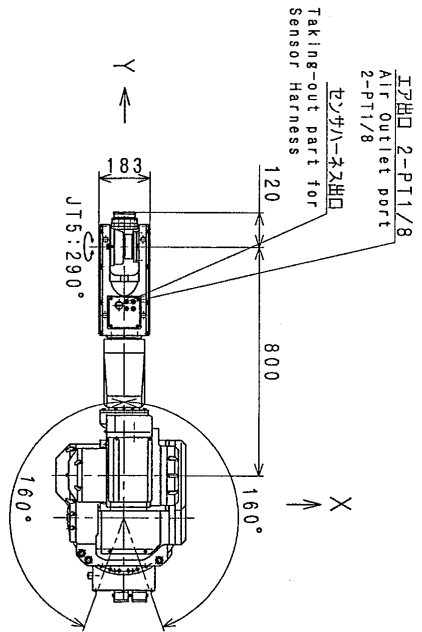
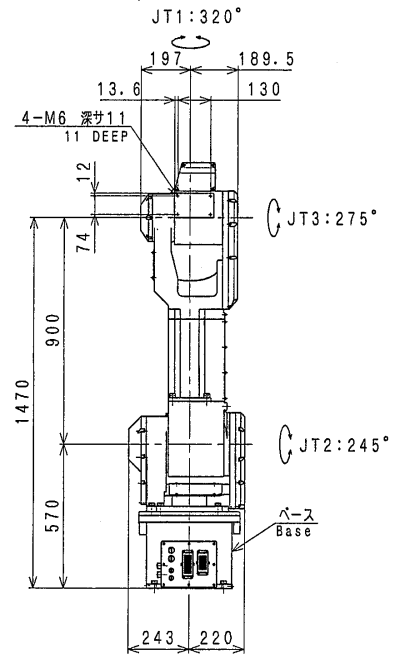
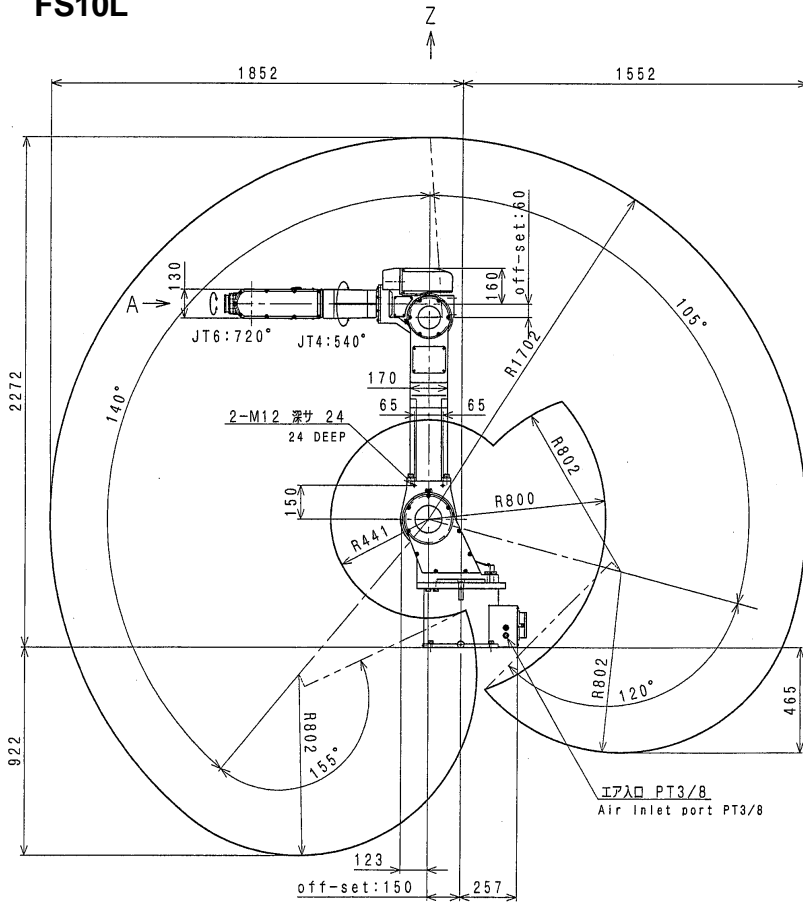

Type	Articulated Robot		
Degree of Freedom	6		
Motion Range and Maximum Speed	JT	Motion Range	Max. Speed
	1	±160°	160 %/s
	2	-105° to +140°	140 %/s
	3	-155° to +120°	160 %/s
	4	±270°	330 %/s
	5	±145°	330 %/s
6	±360°	500 %/s	
Max. Payload	10 kg		
Wrist Load Capacity	JT	Torque	Moment of Inertia
	4	21.5 N·m	0.63 kg·m ²
	5	21.5 N·m	0.63 kg·m ²
6	9.8 N·m	0.15 kg·m ²	
Repeatability	± 0.1 mm		
Mass	Approx. 280 kg		
Acoustic noise	< 70 db (A)*		

*measured condition
 • installed on the plate rigidly fixed on the floor
 • 3200 mm away from JT1 center

The noise level depends on the conditions.

FS10X

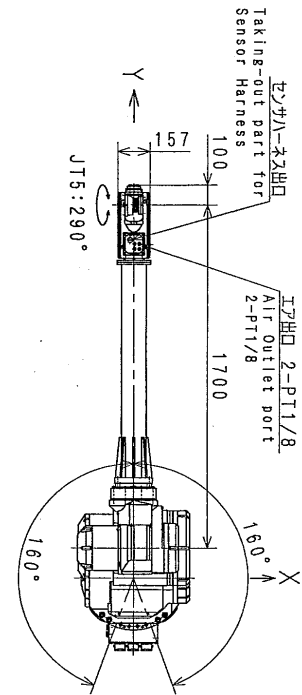
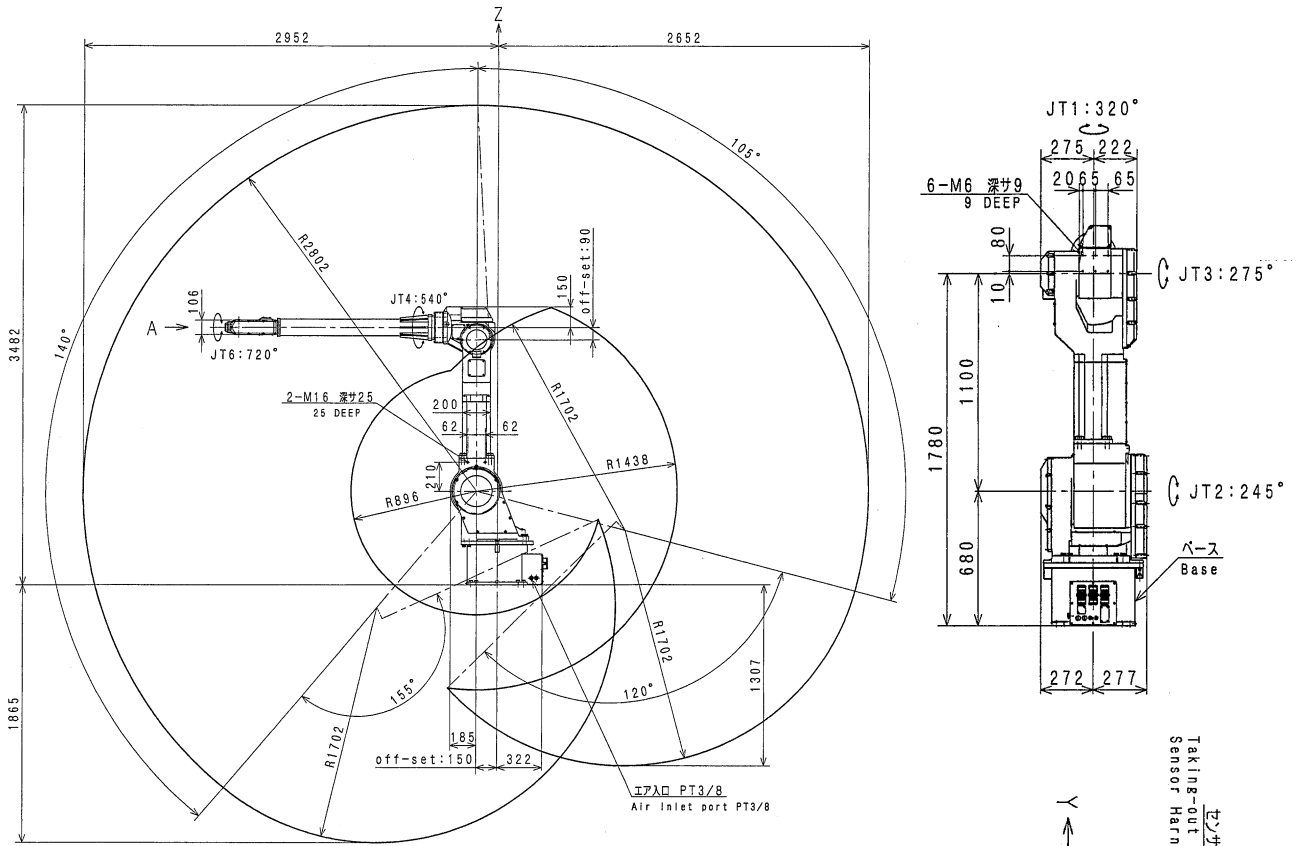

Type	Articulated Robot		
Degree of Freedom	6		
Motion Range and Maximum Speed	JT	Motion Range	Max. Speed
	1	±160°	160 %/s
	2	-105° to +140°	140 %/s
	3	-155° to +120°	200 %/s
	4	±270°	300 %/s
	5	±145°	360 %/s
Max. Payload	10 kg		
Wrist Load Capacity	JT	Torque	Moment of Inertia
	4	21.5 N·m	0.63 kg·m ²
	5	21.5 N·m	0.63 kg·m ²
	6	9.8 N·m	0.15 kg·m ²
Repeatability	±0.23 mm		
Mass	Approx. 580 kg		
Acoustic noise	< 70 db (A)*		

*measured condition
 • installed on the plate rigidly fixed on the floor
 • 4300 mm away from JT1 center

The noise level depends on the conditions.

FS20C

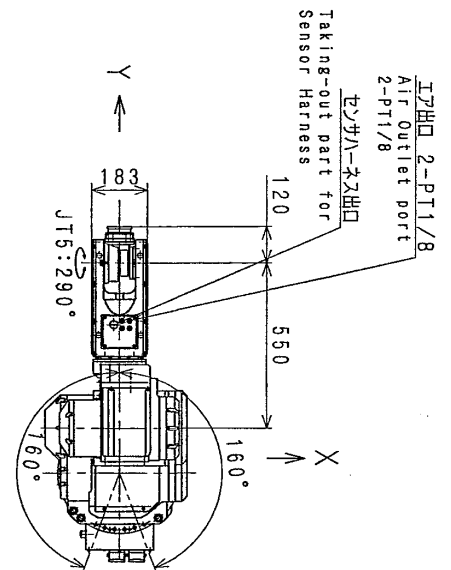
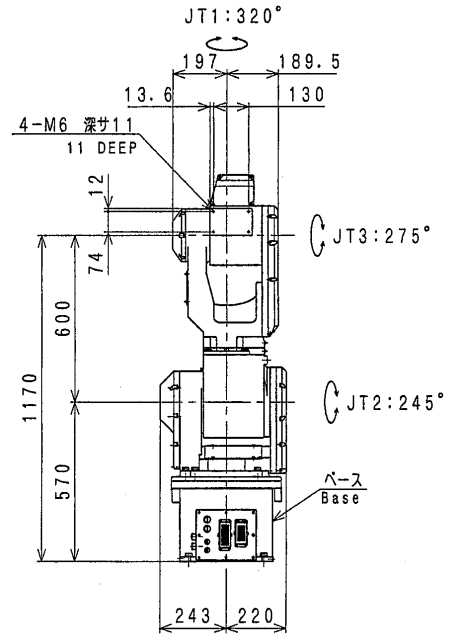
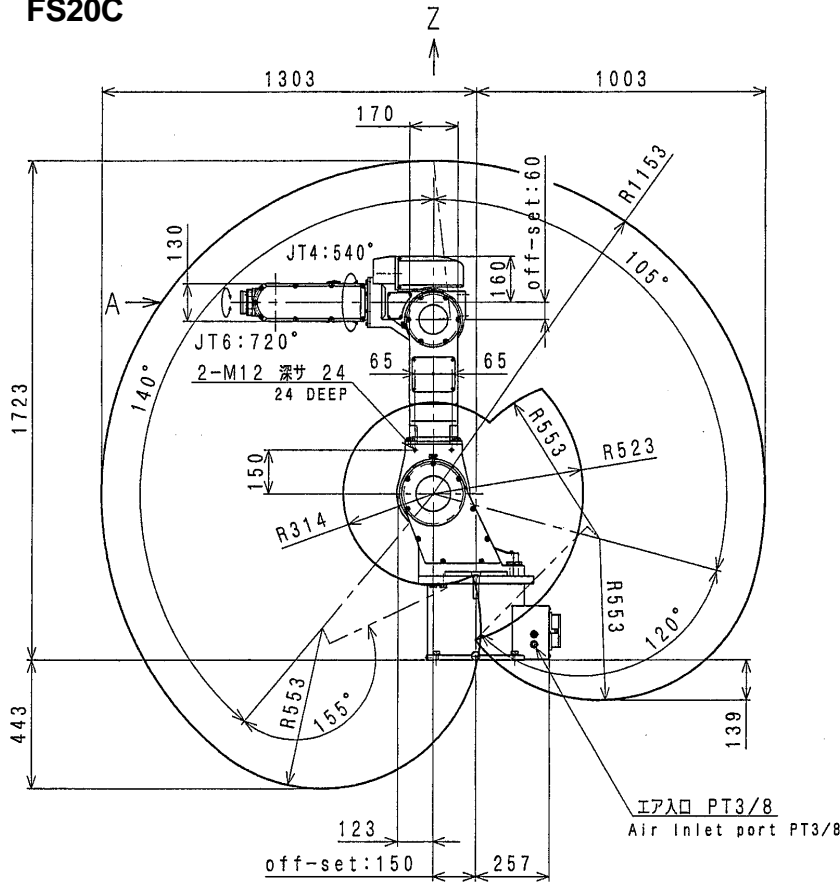

Type	Articulated Robot		
Degree of Freedom	6		
Motion Range and Maximum Speed	JT	Motion Range	Max. Speed
	1	±160°	160 °/s
	2	-105° to +140°	140 °/s
	3	-155° to +120°	160 °/s
	4	±270°	330 °/s
	5	±145°	330 °/s
6	±360°	500 °/s	
Max. Payload	20 kg		
Wrist Load Capacity	JT	Torque	Moment of Inertia
	4	39.3 N·m	0.88 kg·m ²
	5	39.3 N·m	0.88 kg·m ²
6	19.6 N·m	0.25 kg·m ²	
Repeatability	±0.1 mm		
Mass	Approx. 275 kg		
Acoustic noise	< 70 db (A)*		

- *measured condition
- installed on the plate rigidly fixed on the floor
 - 2600 mm away from JT1 center

The noise level depends on the conditions.

FS20N

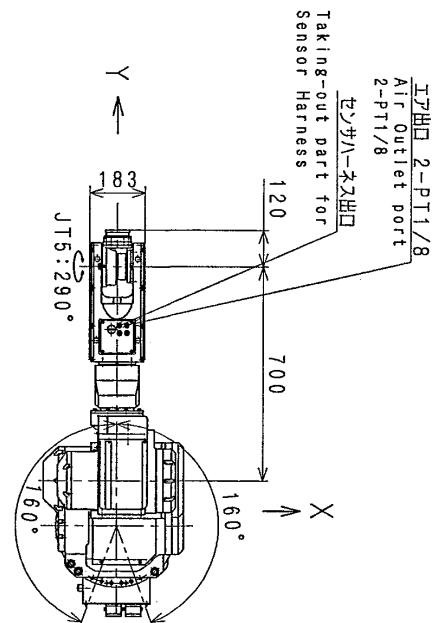
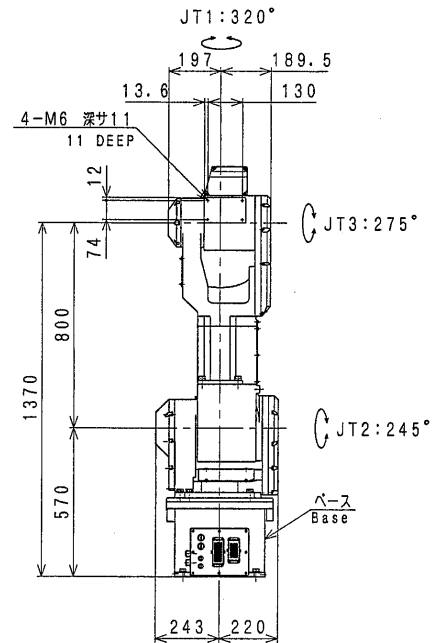
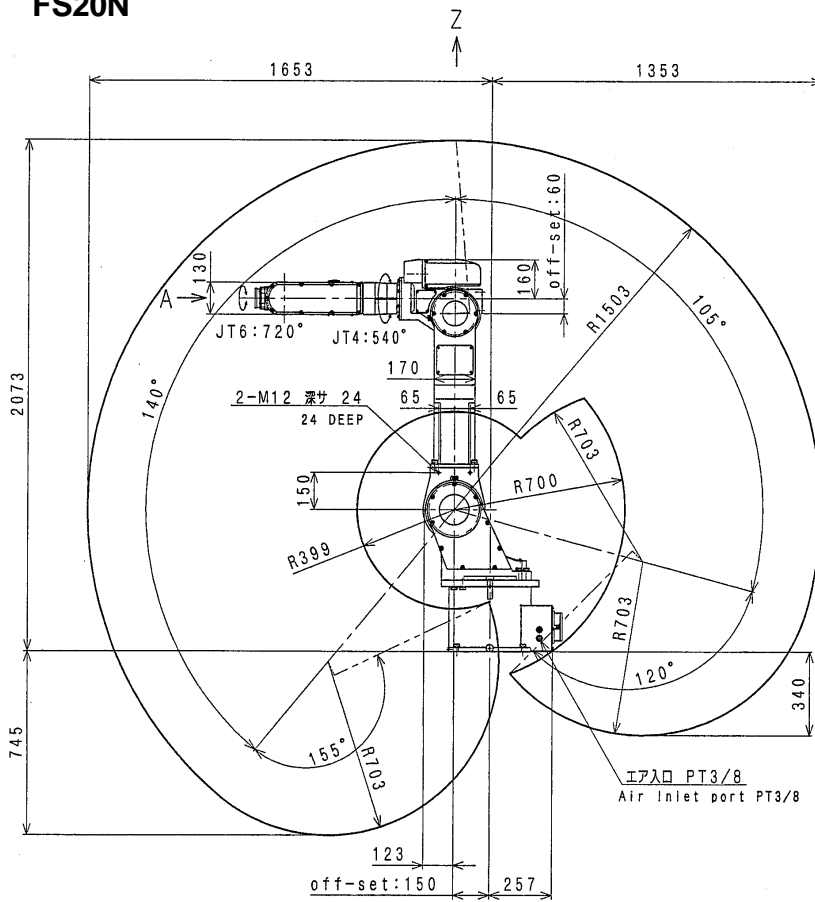

Type	Articulated Robot		
Degree of Freedom	6		
Motion Range and Maximum Speed	JT	Motion Range	Max. Speed
	1	±160°	160 °/s
	2	-105° to +140°	140 °/s
	3	-155° to +120°	160 °/s
	4	±270°	330 °/s
	5	±145°	330 °/s
Max. Payload	20 kg		
Wrist Load Capacity	JT	Torque	Moment of Inertia
	4	39.3 N·m	0.88 kg·m ²
	5	39.3 N·m	0.88 kg·m ²
6	19.6 N·m	0.25 kg·m ²	
Repeatability	±0.1 mm		
Mass	Approx. 280 kg		
Acoustic noise	< 70 db (A)*		

- *measured condition
- installed on the plate rigidly fixed on the floor
 - 2900 mm away from JT1 center

The noise level depends on the conditions.

FS20X

Working range based on point P

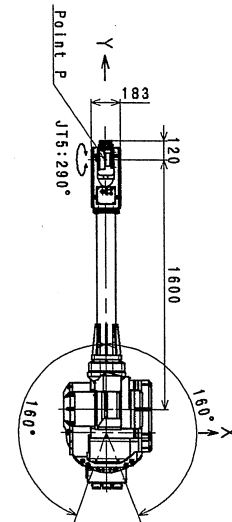
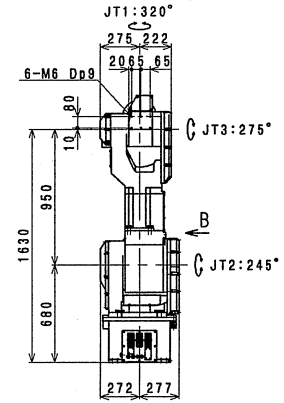
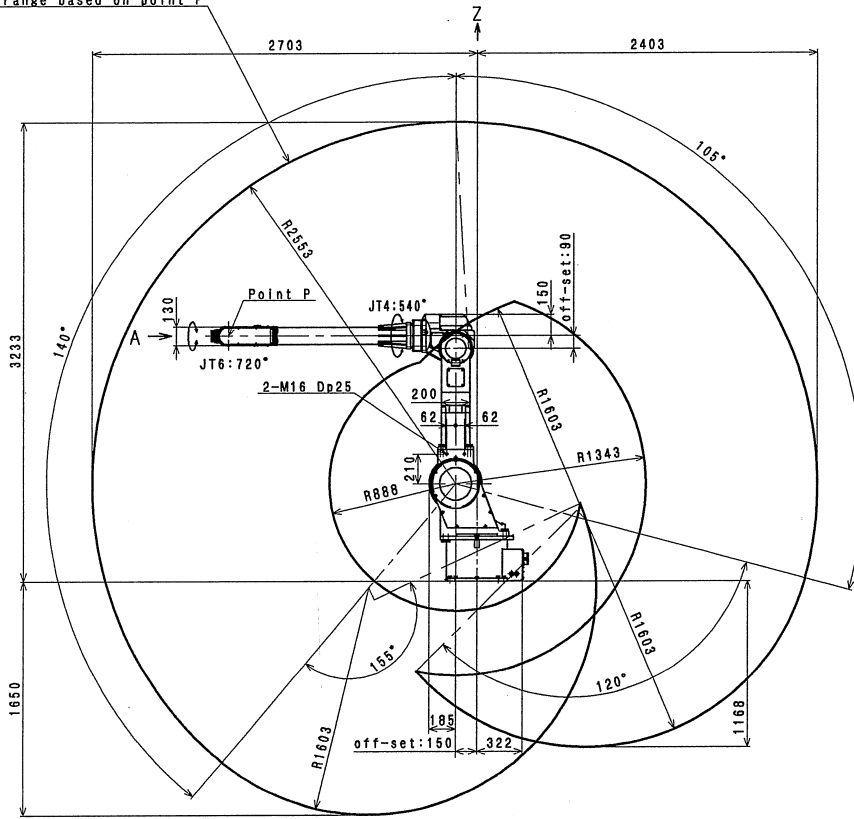

Type	Articulated Robot		
Degree of Freedom	6		
Motion Range and Maximum Speed	JT	Motion Range	Max. Speed
	1	±160°	160 °/s
	2	-105° to +140°	140 °/s
	3	-155° to +120°	200 °/s
	4	±270°	300 °/s
	5	±145°	330 °/s
6	±360°	500 °/s	
Max. Payload	20 kg		
Wrist Load Capacity	JT	Torque	Moment of Inertia
	4	39.3 N·m	0.88 kg·m ²
	5	39.3 N·m	0.88 kg·m ²
6	19.6 N·m	0.25 kg·m ²	
Repeatability	±0.5 mm		
Mass	Approx. 585 kg		
Acoustic noise	< 70 db (A)*		

- *measured condition
- installed on the plate rigidly fixed on the floor
 - 4000 mm away from JT1 center

The noise level depends on the conditions.

FS30N

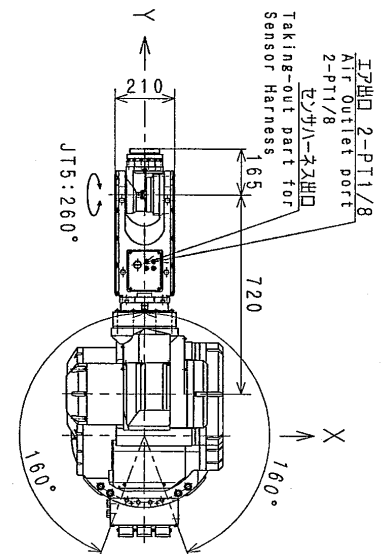
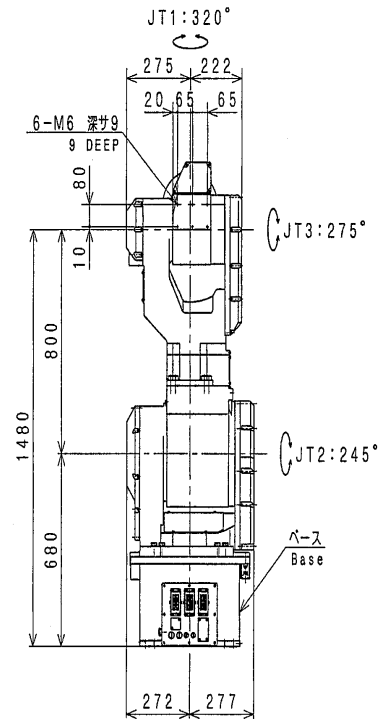
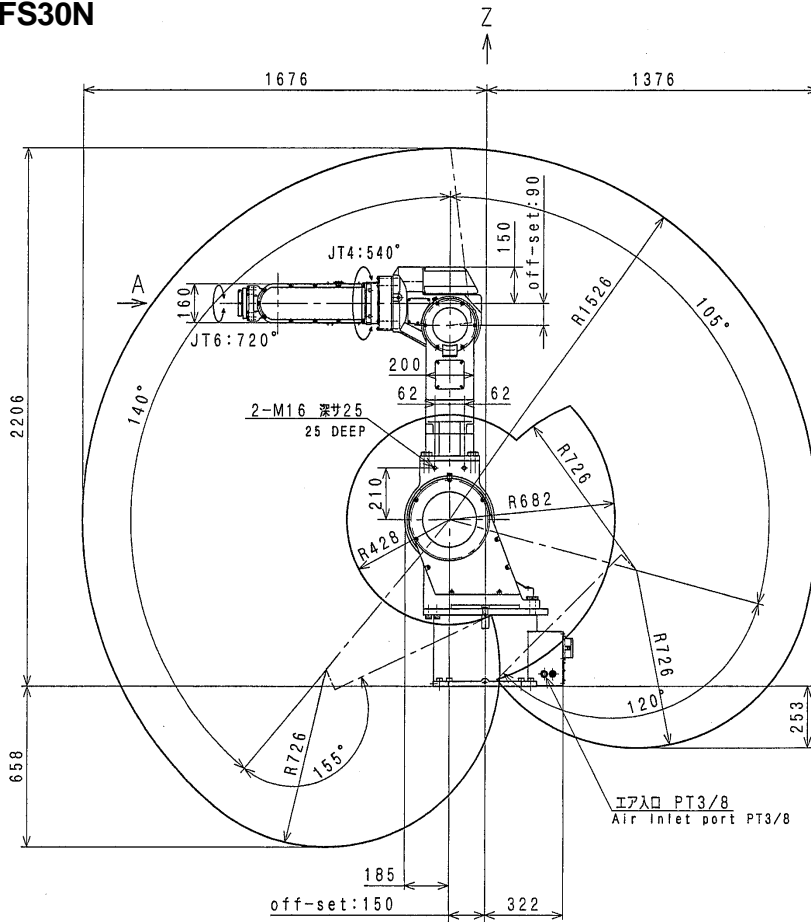

Type	Articulated Robot		
Degree of Freedom	6		
Motion Range and Maximum Speed	JT	Motion Range	Max. Speed
	1	±160°	160 °/s
	2	-105° to +140°	140 °/s
	3	-155° to +120°	160 °/s
	4	±270°	240 °/s
	5	±130°	240 °/s
6	±360°	340 °/s	
Max. Payload	30 kg		
Wrist Load Capacity	JT	Torque	Moment of Inertia
	4	176.4N·m	7.2 kg·m ²
	5	176.4N·m	7.2 kg·m ²
6	98.0 N·m	3.3 kg·m ²	
Repeatability	±0.15 mm		
Mass	Approx. 575 kg		
Acoustic noise	< 70 db (A)*		

*measured condition
 • installed on the plate rigidly fixed on the floor
 • 3700 mm away from JT1 center

〔 The noise level depends on the conditions. 〕

FS30L

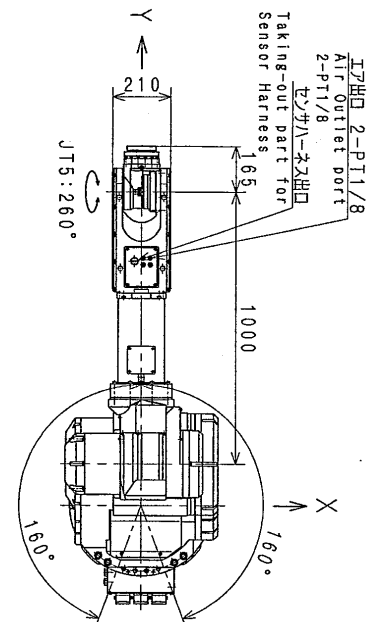
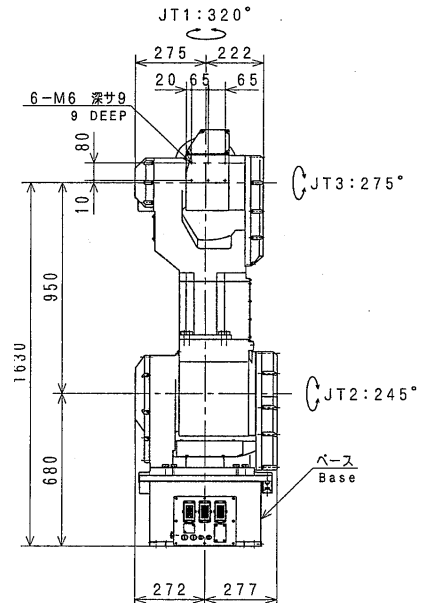
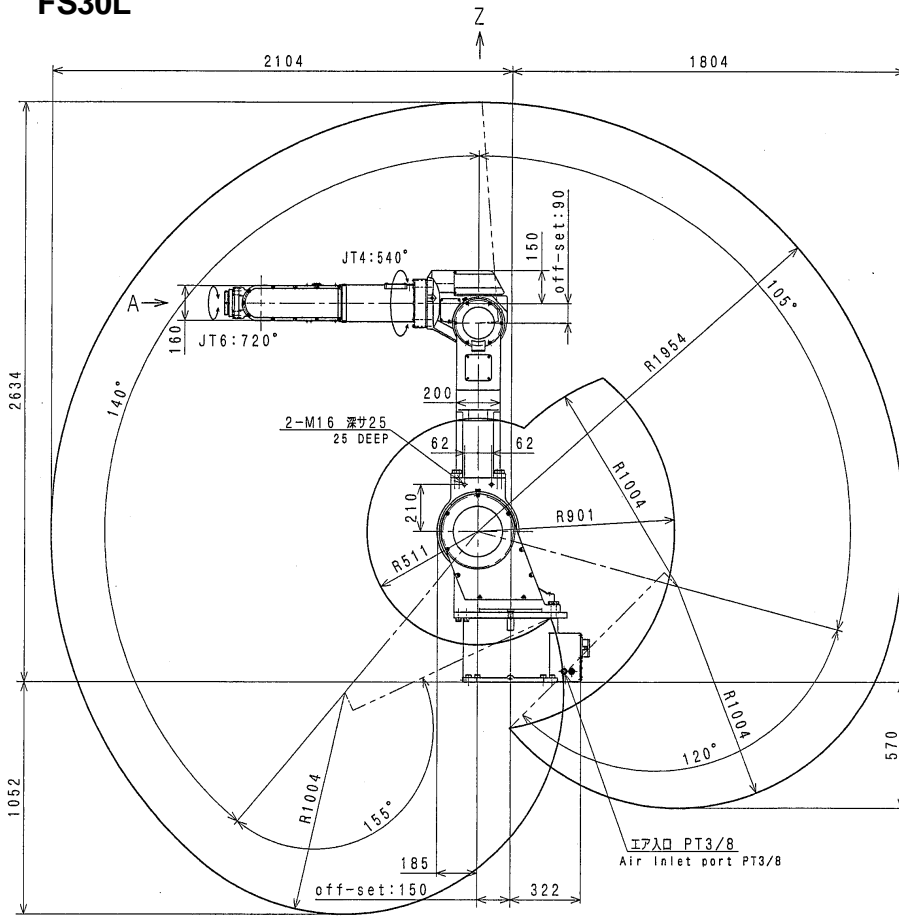

Type	Articulated Robot		
Degree of Freedom	6		
Motion Range and Maximum Speed	JT	Motion Range	Max. Speed
	1	±160°	160 °/s
	2	-105° to +140°	140 °/s
	3	-155° to +120°	160 °/s
	4	±270°	240 °/s
	5	±130°	240 °/s
6	±360°	340 °/s	
Max. Payload	30 kg		
Wrist Load Capacity	JT	Torque	Moment of Inertia
	4	176.4N·m	7.2 kg·m ²
	5	176.4N·m	7.2 kg·m ²
6	98.0 N·m	3.3 kg·m ²	
Repeatability	±0.15 mm		
Mass	Approx. 585 kg		
Acoustic noise	< 70 db (A)*		

*measured condition

- installed on the plate rigidly fixed on the floor
- 4100 mm away from JT1 center

The noise level depends on the conditions.

FS45C

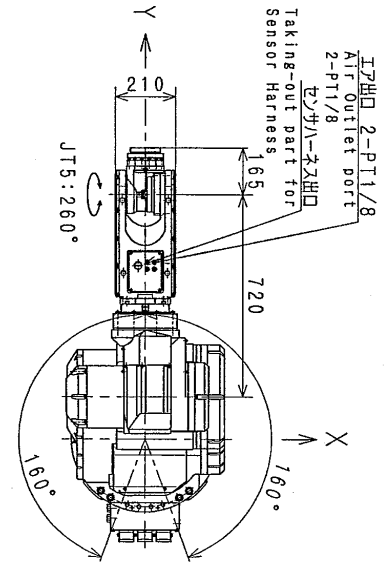
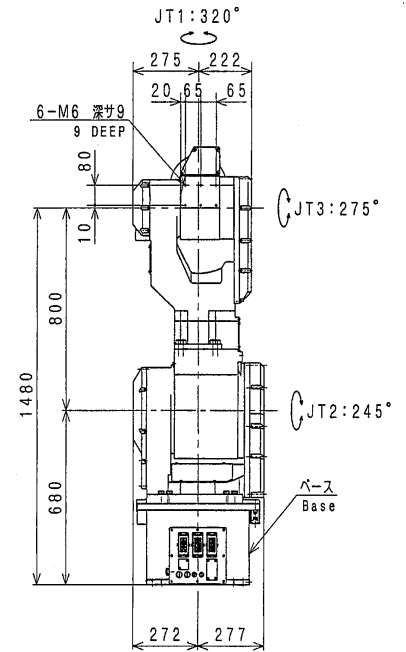
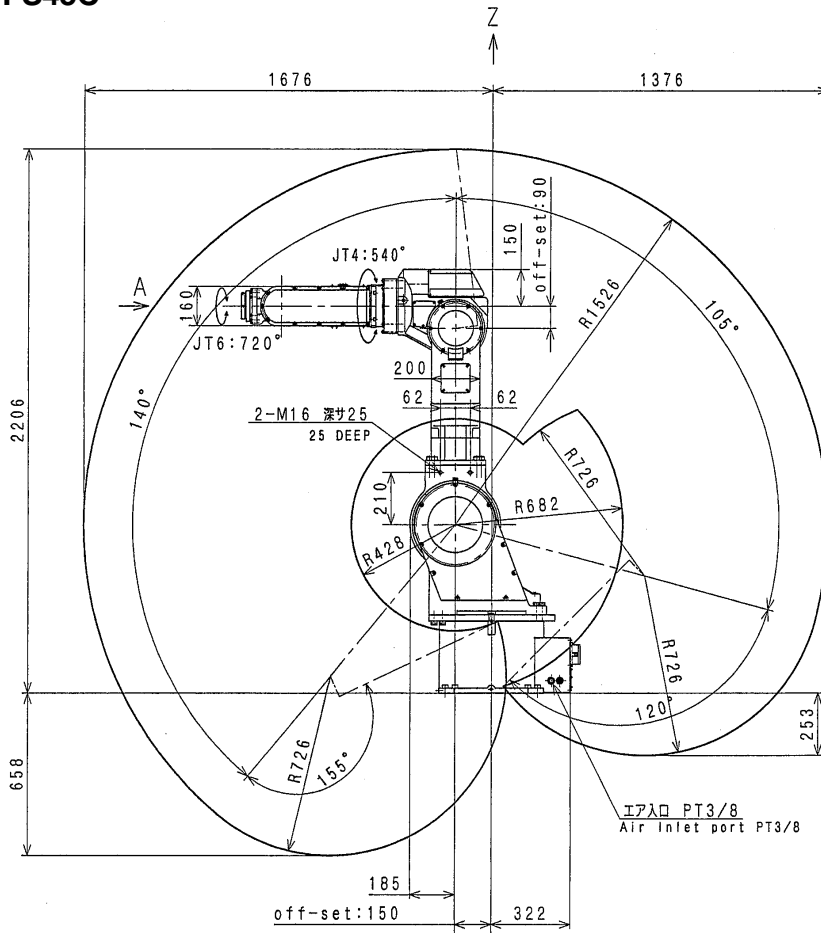

Type	Articulated Robot		
Degree of Freedom	6		
Motion Range and Maximum Speed	JT	Motion Range	Max. Speed
	1	±160°	160 °/s
	2	-105° to +140°	140 °/s
	3	-155° to +120°	160 °/s
	4	±270°	240 °/s
	5	±130°	240 °/s
Max. Payload	45 kg		
Wrist Load Capacity	JT	Torque	Moment of Inertia
	4	176.4N·m	10.8 kg·m ²
	5	176.4N·m	10.8 kg·m ²
6	98.0 N·m	5.0 kg·m ²	
Repeatability	±0.15 mm		
Mass	Approx. 575 kg		
Acoustic noise	< 70 db (A)*		

*measured condition

- installed on the plate rigidly fixed on the floor
- 3300 mm away from JT1 center

The noise level depends on the conditions.

FS45N

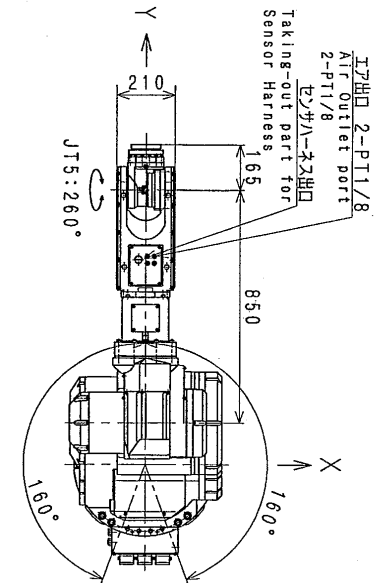
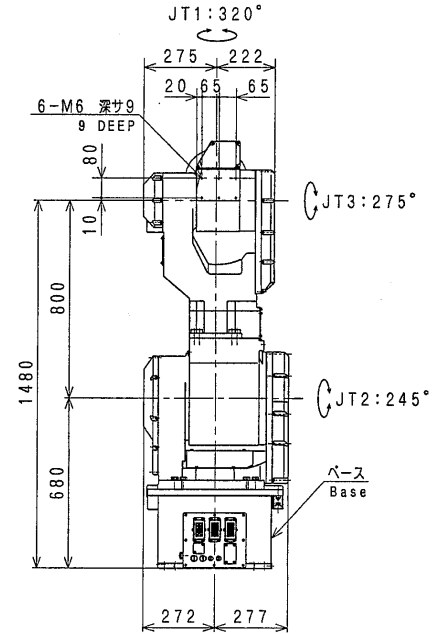
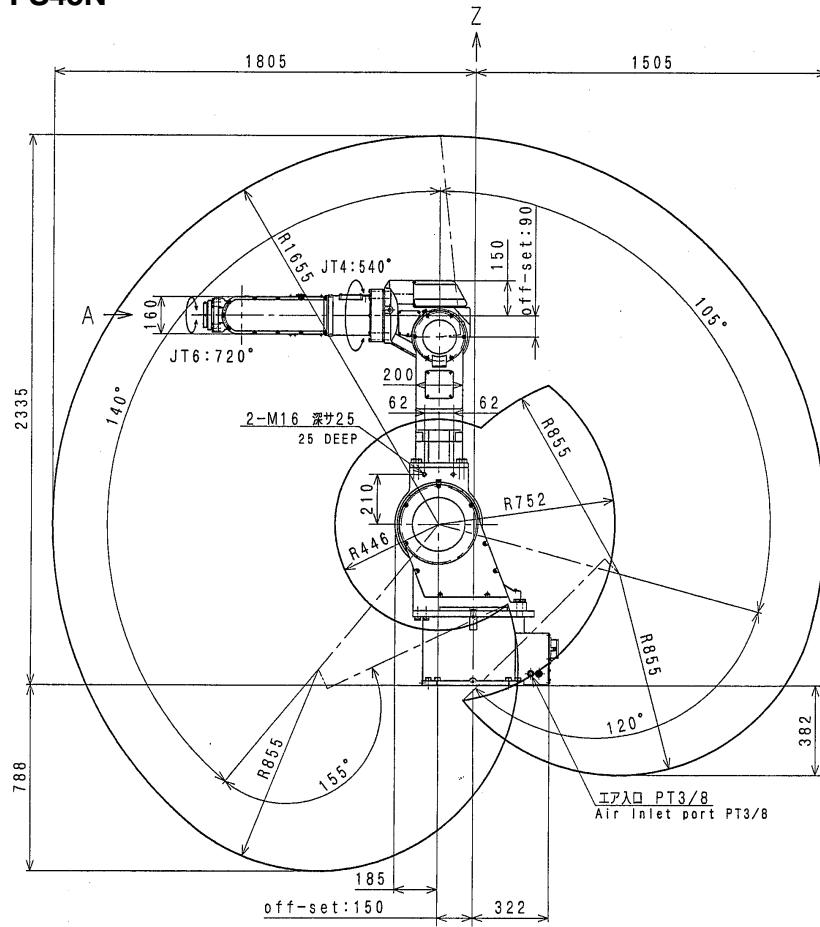

Type	Articulated Robot		
Degree of Freedom	6		
Motion Range and Maximum Speed	JT	Motion Range	Max. Speed
	1	±160°	160 °/s
	2	-105° to +140°	140 °/s
	3	-155° to +120°	160 °/s
	4	±270°	240 °/s
	5	±130°	240 °/s
6	±360°	340 °/s	
Max. Payload	45 kg		
Wrist Load Capacity	JT	Torque	Moment of Inertia
	4	176.4N·m	10.8 kg·m ²
	5	176.4N·m	10.8 kg·m ²
6	98.0 N·m	5.0 kg·m ²	
Repeatability	±0.15 mm		
Mass	Approx. 580 kg		
Acoustic noise	< 70 db (A)*		

*measured condition

- installed on the plate rigidly fixed on the floor
- 3400 mm away from JT1 center

The noise level depends on the conditions.

FS60L

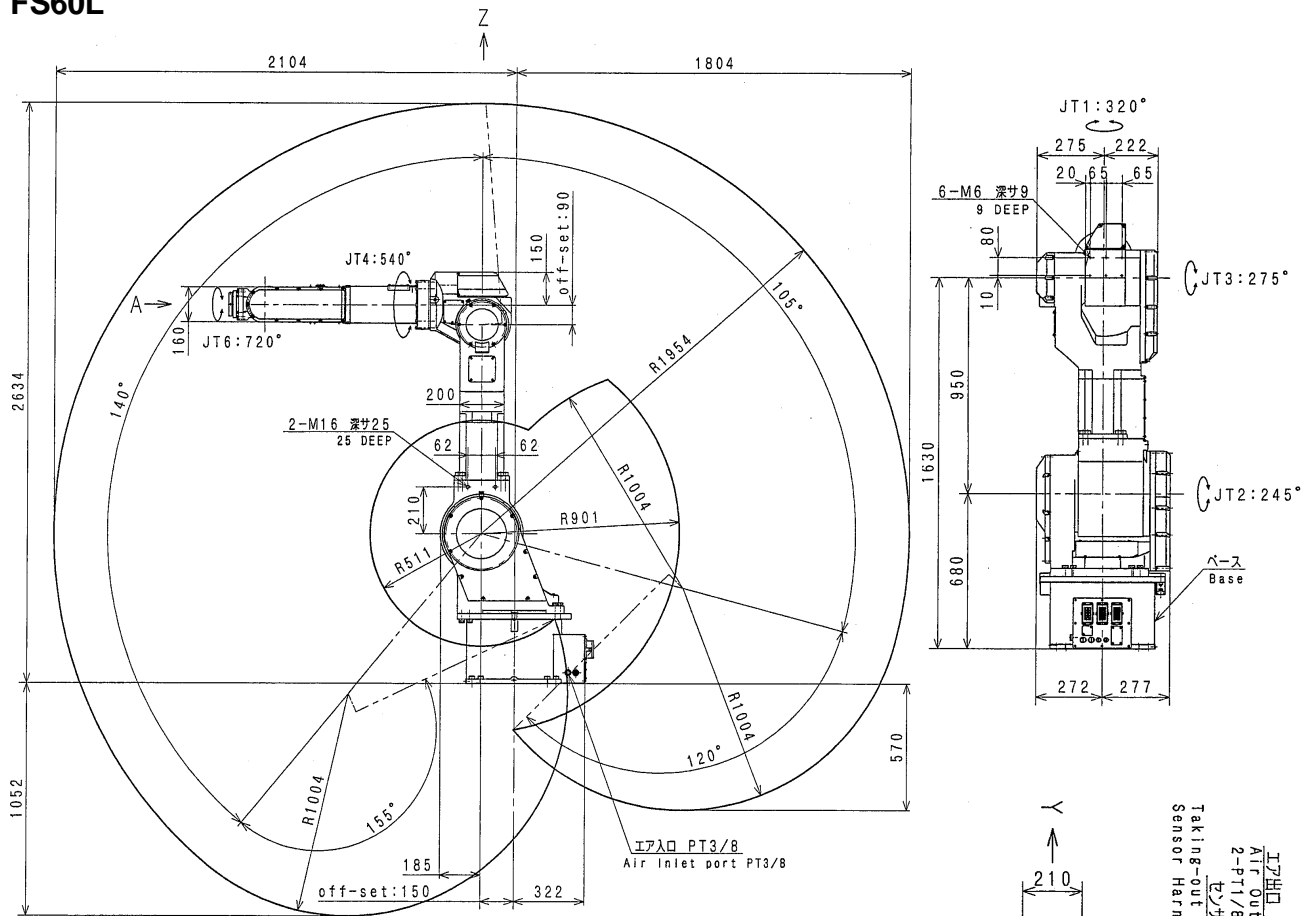

Type	Articulated Robot		
Degree of Freedom	6		
Motion Range and Maximum Speed	JT	Motion Range	Max. Speed
	1	±160°	160 °/s
	2	-105° to +140°	100 °/s
	3	-155° to +120°	110 °/s
	4	±270°	180 °/s
	5	±130°	175 °/s
6	±360°	260 °/s	
Max. Payload	60 kg		
Wrist Load Capacity	JT	Torque	Moment of Inertia
	4	235.2N·m	24.8 kg·m ²
	5	235.2N·m	24.8 kg·m ²
6	130.3 N·m	6.7 kg·m ²	
Repeatability	±0.15 mm		
Mass	Approx. 585 kg		
Acoustic noise	< 70 db (A)*		

- *measured condition
- installed on the plate rigidly fixed on the floor
 - 3700 mm away from JT1 center

The noise level depends on the conditions.

FA06N

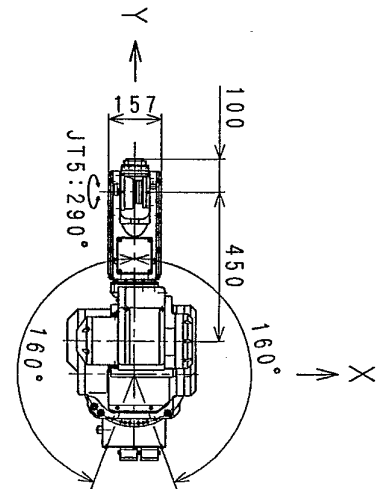
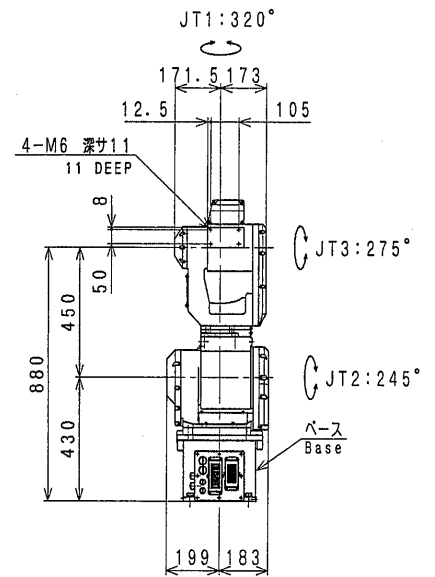
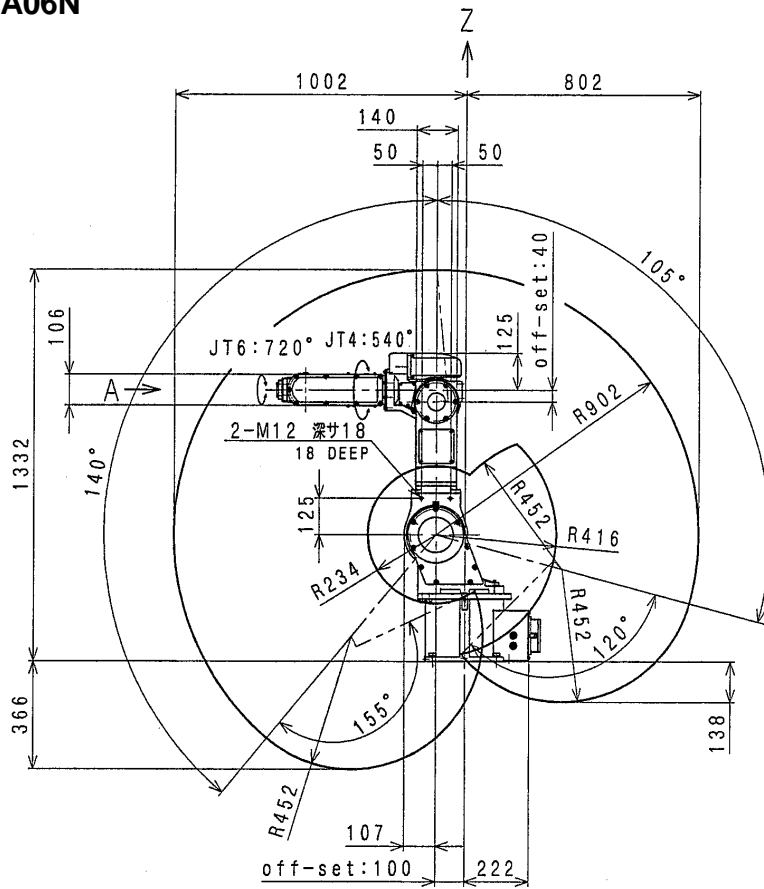

Type	Articulated Robot		
Degree of Freedom	6		
Motion Range and Maximum Speed	JT	Motion Range	Max. Speed
	1	±160°	240 °/s
	2	-105° to +140°	200 °/s
	3	-155° to +120°	250 °/s
	4	±270°	430 °/s
	5	±145°	430 °/s
6	±360°	720 °/s	
Max. Payload	6 kg		
Wrist Load Capacity	JT	Torque	Moment of Inertia
	4	12.0 N·m	0.24 kg·m ²
	5	12.0 N·m	0.24 kg·m ²
6	6.0 N·m	0.07 kg·m ²	
Repeatability	±0.05 mm		
Mass	Approx. 165 kg		
Acoustic noise	< 70 db (A)*		

*measured condition

- installed on the plate rigidly fixed on the floor
- 2300 mm away from JT1 center

The noise level depends on the conditions.

FA06E

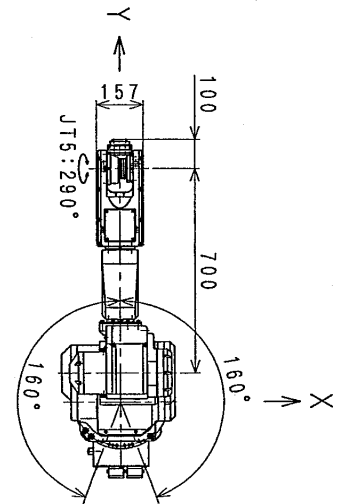
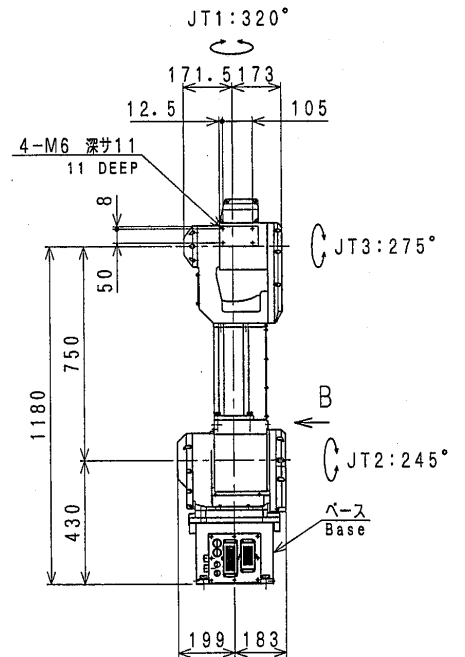
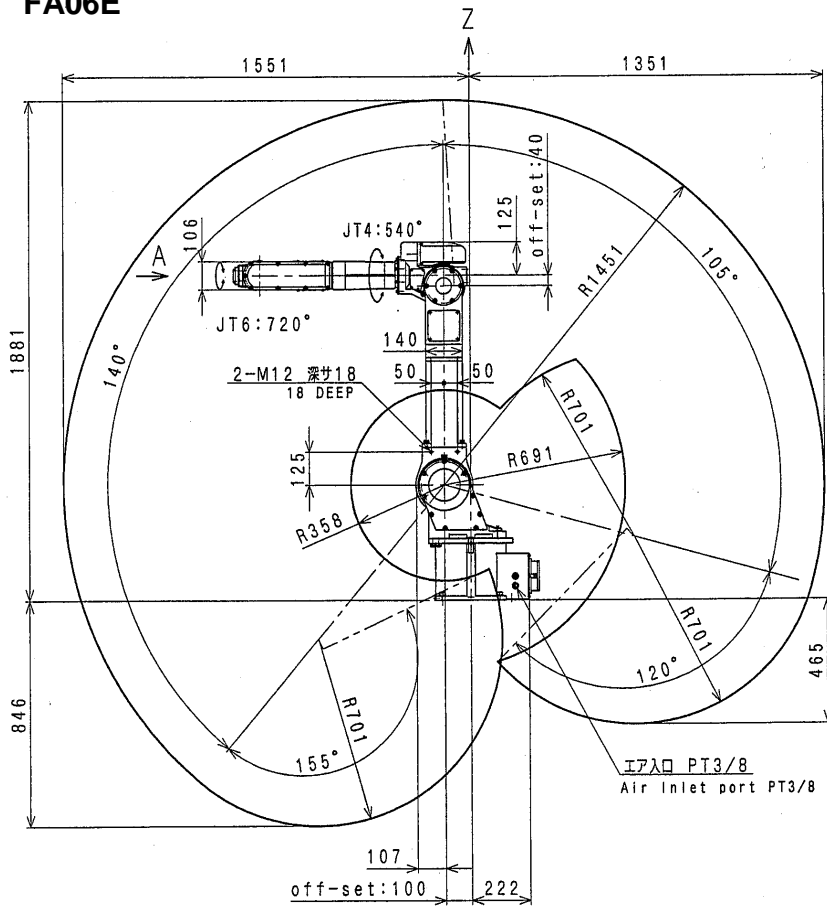

Type	Articulated Robot		
Degree of Freedom	6		
Motion Range and Maximum Speed	JT	Motion Range	Max. Speed
	1	±160°	200 °/s
	2	-105° to +140°	140 °/s
	3	-155° to +120°	200 °/s
	4	±270°	360 °/s
	5	±145°	360 °/s
Max. Payload	6 kg		
Wrist Load Capacity	JT	Torque	Moment of Inertia
	4	12.0 N·m	0.24 kg·m ²
	5	12.0 N·m	0.24 kg·m ²
6	6.0 N·m	0.07 kg·m ²	
Repeatability	±0.1 mm		
Mass	Approx. 170 kg		
Acoustic noise	< 70 db (A)*		

- *measured condition
- installed on the plate rigidly fixed on the floor
 - 2900 mm away from JT1 center

The noise level depends on the conditions.

FA10N

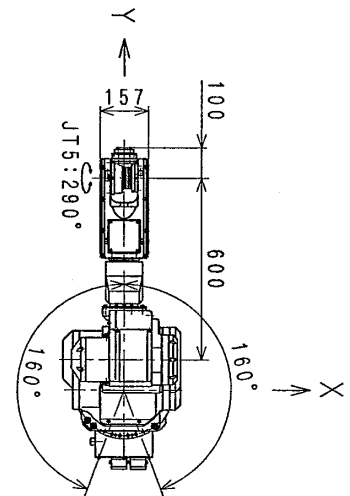
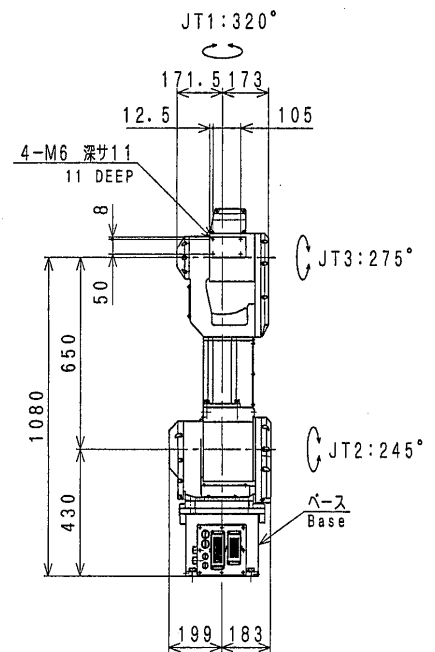
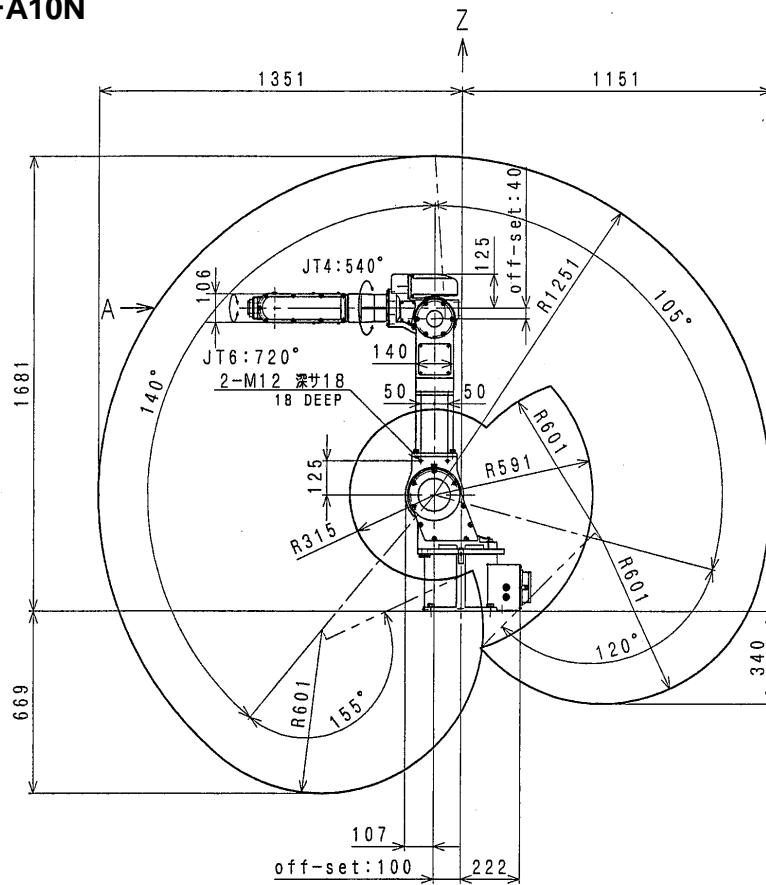

Type	Articulated Robot		
Degree of Freedom	6		
Motion Range and Maximum Speed	JT	Motion Range	Max. Speed
	1	±160°	200 °/s
	2	-105° to +140°	140 °/s
	3	-155° to +120°	200 °/s
	4	±270°	360 °/s
	5	±145°	360 °/s
6	±360°	600 °/s	
Max. Payload	10 kg		
Wrist Load Capacity	JT	Torque	Moment of Inertia
	4	21.5 N·m	0.63 kg·m ²
	5	21.5 N·m	0.63 kg·m ²
6	9.8 N·m	0.15 kg·m ²	
Repeatability	±0.1 mm		
Mass	Approx. 170 kg		
Acoustic noise	< 70 db (A)*		

*measured condition
 • installed on the plate rigidly fixed on the floor
 • 2700 mm away from JT1 center

The noise level depends on the conditions.

FA10L

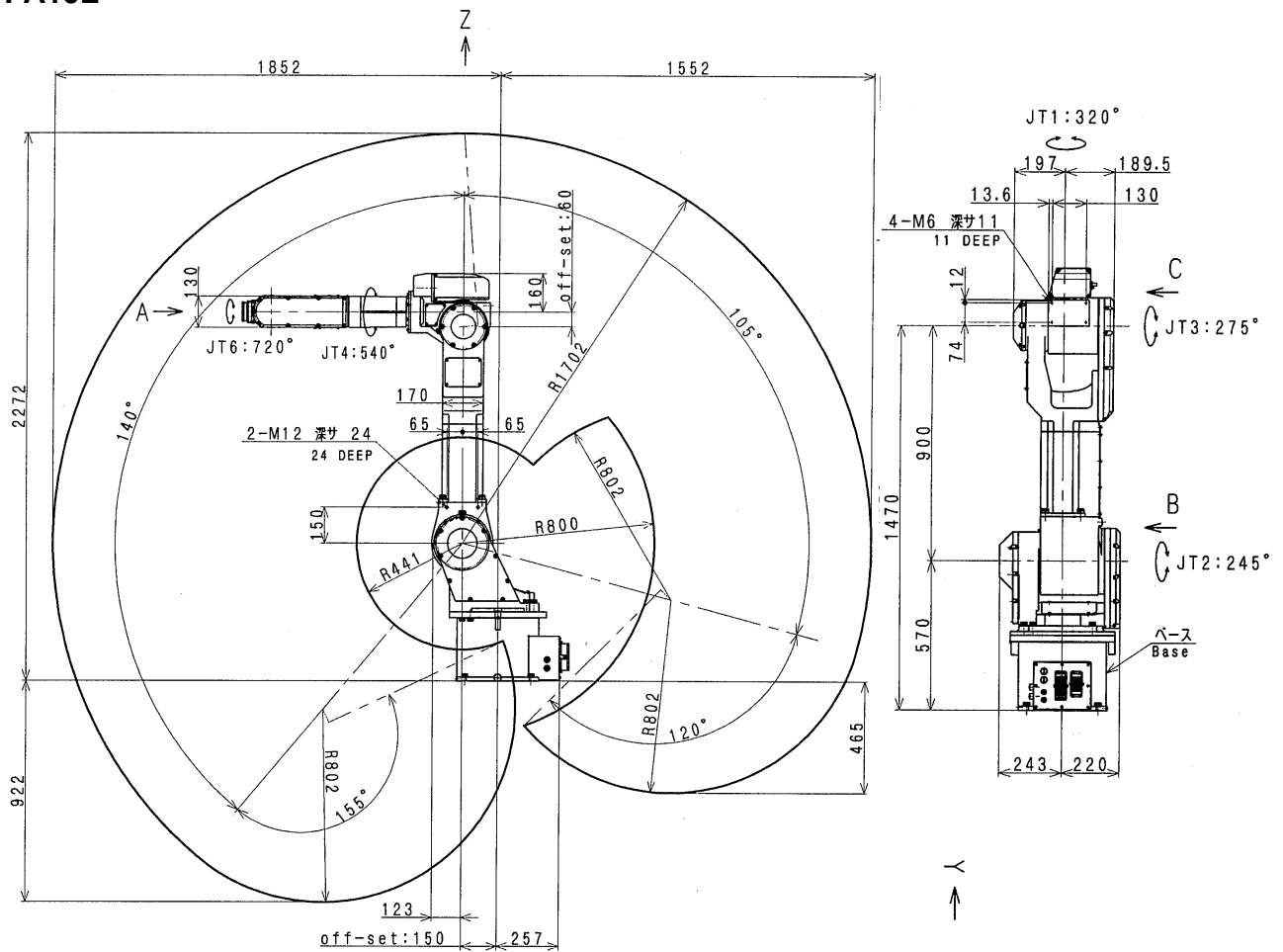

Type	Articulated Robot		
Degree of Freedom	6		
Motion Range and Maximum Speed	JT	Motion Range	Max. Speed
	1	±160°	160 °/s
	2	-105° to +140°	140 °/s
	3	-155° to +120°	160 °/s
	4	±270°	330 °/s
	5	±145°	330 °/s
6	±360°	500 °/s	
Max. Payload	10 kg		
Wrist Load Capacity	JT	Torque	Moment of Inertia
	4	21.5 N·m	0.63 kg·m ²
	5	21.5 N·m	0.63 kg·m ²
6	9.8 N·m	0.15 kg·m ²	
Repeatability	±0.1 mm		
Mass	Approx. 280 kg		
Acoustic noise	< 70 db (A)*		

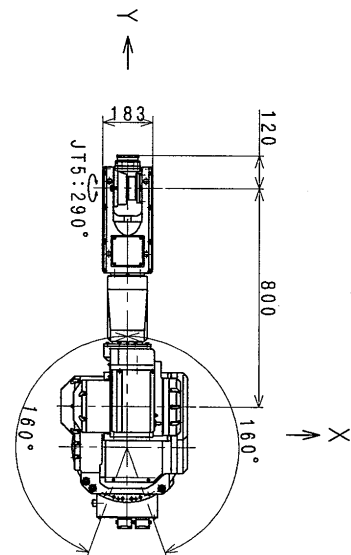

*measured condition
 • installed on the plate rigidly fixed on the floor
 • 3200 mm away from JT1 center

[The noise level depends on the conditions.]

FA20N

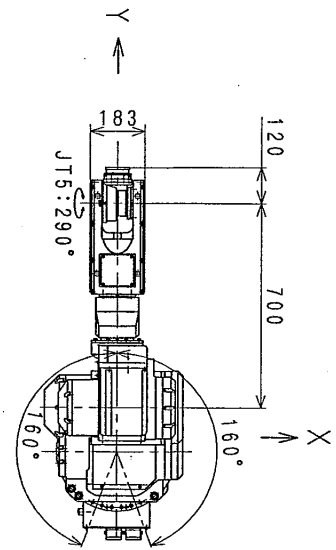
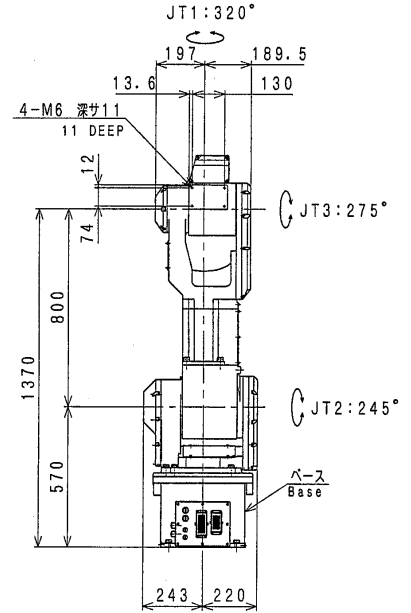
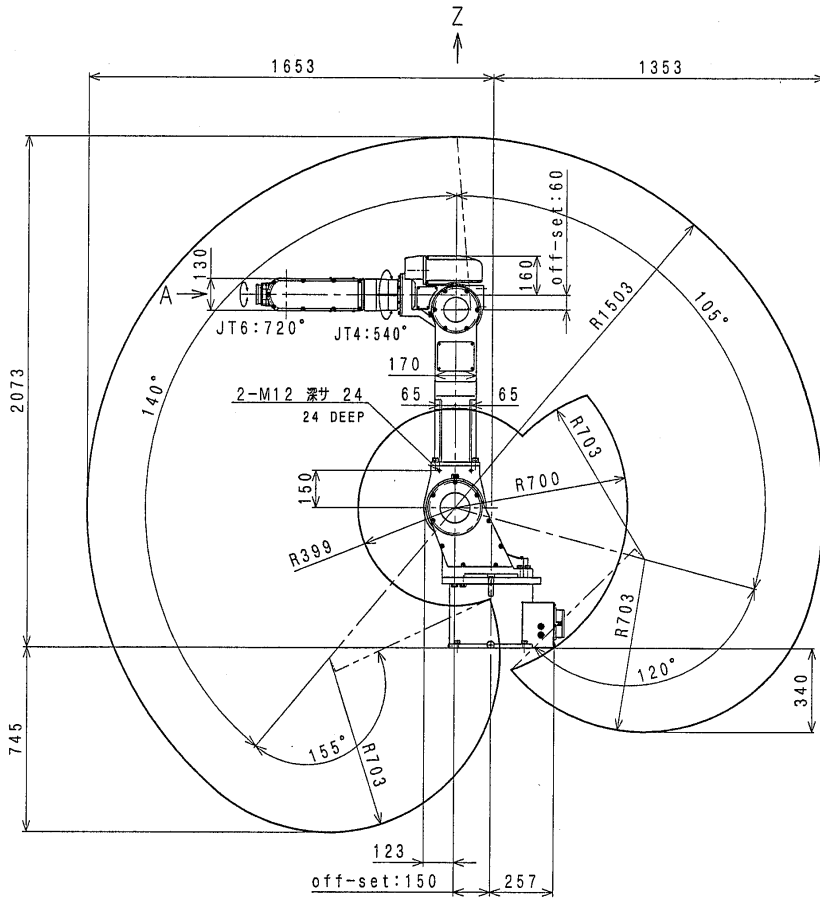

Type	Articulated Robot		
Degree of Freedom	6		
Motion Range and Maximum Speed	JT	Motion Range	Max. Speed
	1	±160°	160 °/s
	2	-105° to +140°	140 °/s
	3	-155° to +120°	160 °/s
	4	±270°	330 °/s
	5	±145°	330 °/s
6	±360°	500 °/s	
Max. Payload	20 kg		
Wrist Load Capacity	JT	Torque	Moment of Inertia
	4	39.3 N·m	0.88 kg·m ²
	5	39.3 N·m	0.88 kg·m ²
6	19.6 N·m	0.25 kg·m ²	
Repeatability	±0.1 mm		
Mass	Approx. 280 kg		
Acoustic noise	< 70 db (A)*		

*measured condition
 • installed on the plate rigidly fixed on the floor
 • 2900 mm away from JT1 center

〔 The noise level depends on the conditions. 〕

FA30L

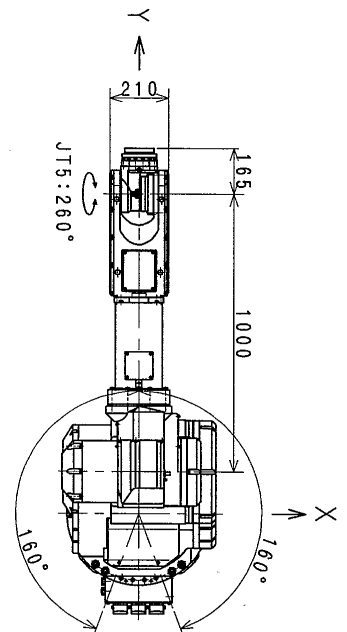
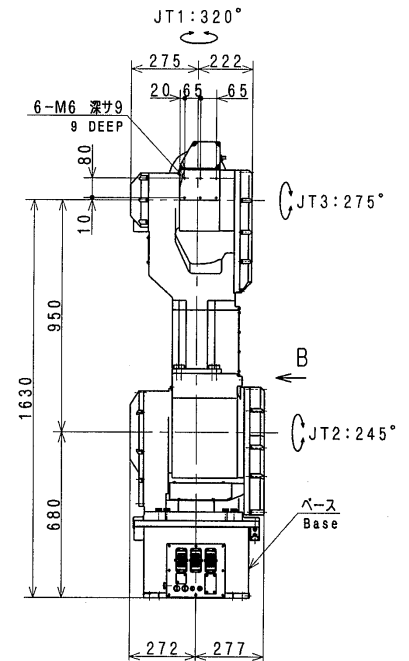
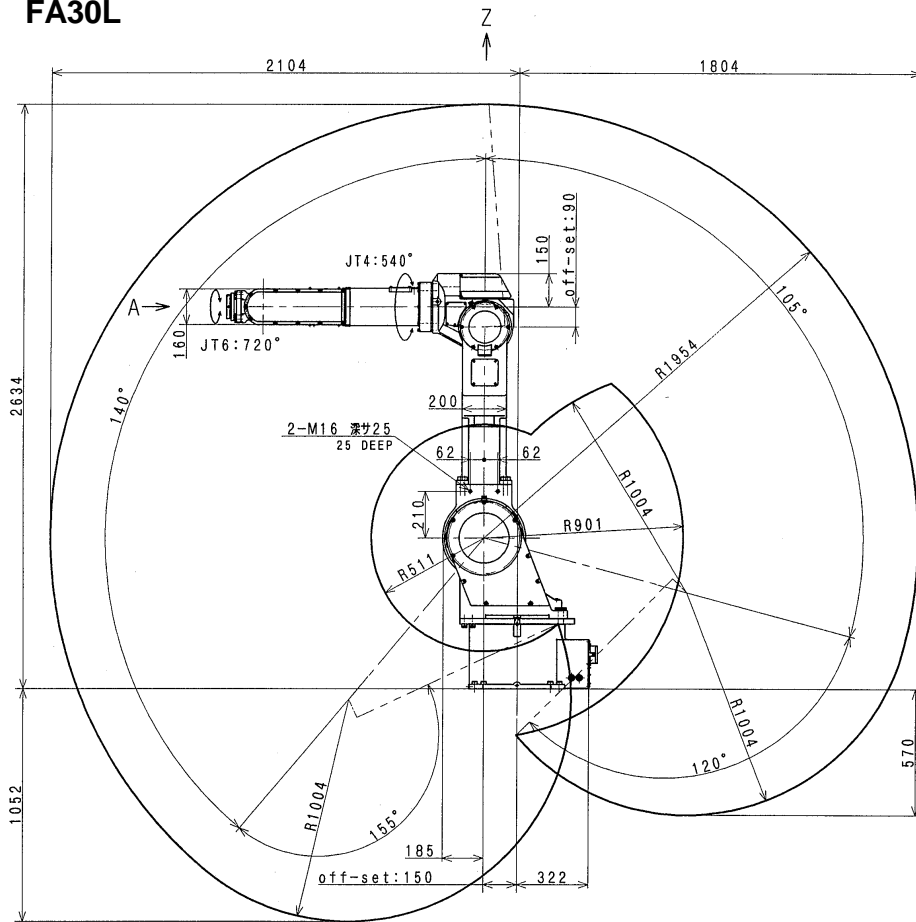

Type	Articulated Robot		
Degree of Freedom	6		
Motion Range and Maximum Speed	JT	Motion Range	Max. Speed
	1	±160°	160 °/s
	2	-105° to +140°	140 °/s
	3	-155° to +120°	160 °/s
	4	±270°	240 °/s
	5	±130°	240 °/s
6	±360°	340 °/s	
Max. Payload	30 kg		
Wrist Load Capacity	JT	Torque	Moment of Inertia
	4	176.4 N·m	7.2 kg·m ²
	5	176.4 N·m	7.2 kg·m ²
6	98.0 N·m	3.3 kg·m ²	
Repeatability	±0.15 mm		
Mass	Approx. 585 kg		
Acoustic noise	< 70 db (A)*		

*measured condition
 • installed on the plate rigidly fixed on the floor
 • 4100 mm away from JT1 center

The noise level depends on the conditions.

FC06N

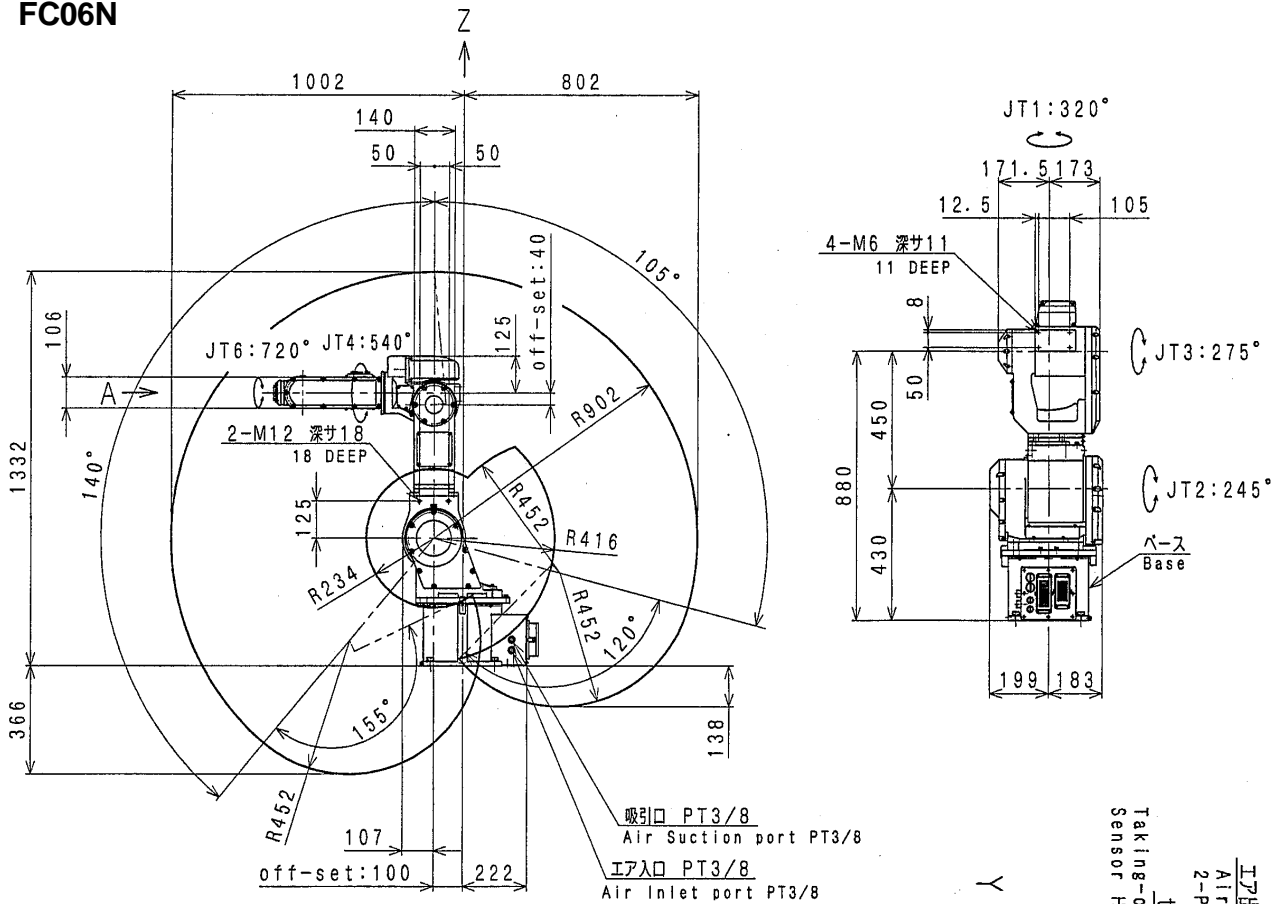

Type	Articulated Robot		
Degree of Freedom	6		
Motion Range and Maximum Speed	JT	Motion Range	Max. Speed
	1	±160°	240 °/s
	2	-105° to +140°	200 °/s
	3	-155° to +120°	250 °/s
	4	±270°	430 °/s
	5	±145°	430 °/s
6	±360°	720 °/s	
Max. Payload	6 kg		
Wrist Load Capacity	JT	Torque	Moment of Inertia
	4	12.0 N·m	0.24 kg·m ²
	5	12.0 N·m	0.24 kg·m ²
6	6.0 N·m	0.07 kg·m ²	
Repeatability	±0.05 mm		
Mass	Approx. 165 kg		
Acoustic noise	< 70 db (A)*		

*measured condition
 • installed on the plate rigidly fixed on the floor
 • 2300 mm away from JT1 center

The noise level depends on the conditions.

FC06L

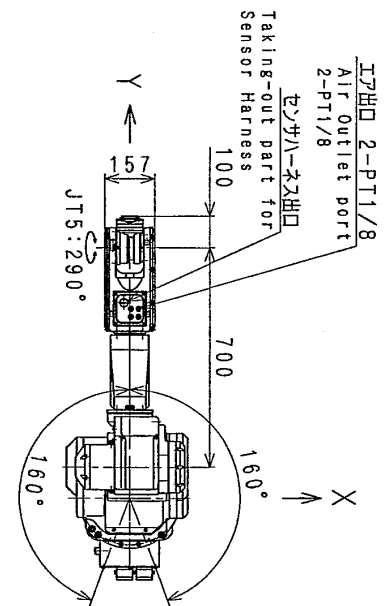
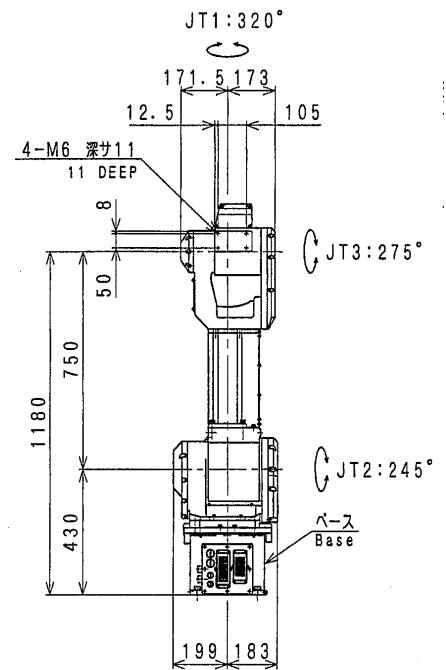
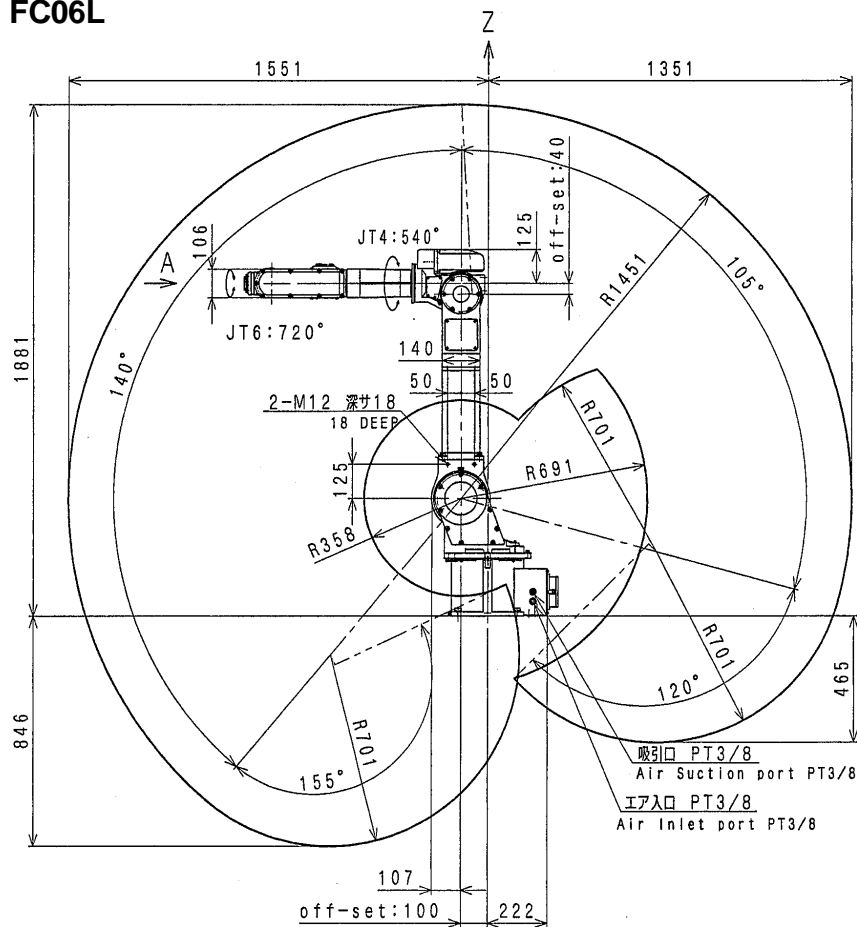

Type	Articulated Robot		
Degree of Freedom	6		
Motion Range and Maximum Speed	JT	Motion Range	Max. Speed
	1	±160°	200 %/s
	2	-105° to +140°	140 %/s
	3	-155° to +120°	200 %/s
	4	±270°	360 %/s
	5	±145°	360 %/s
6	±360°	600 %/s	
Max. Payload	6 kg		
Wrist Load Capacity	JT	Torque	Moment of Inertia
	4	12.0 N·m	0.24 kg·m ²
	5	12.0 N·m	0.24 kg·m ²
6	6.0 N·m	0.07 kg·m ²	
Repeatability	±0.01 mm		
Mass	Approx. 170 kg		
Acoustic noise	< 70 db (A)*		

*measured condition
 • installed on the plate rigidly fixed on the floor
 • 2900 mm away from JT1 center

The noise level depends on the conditions.

FC10N

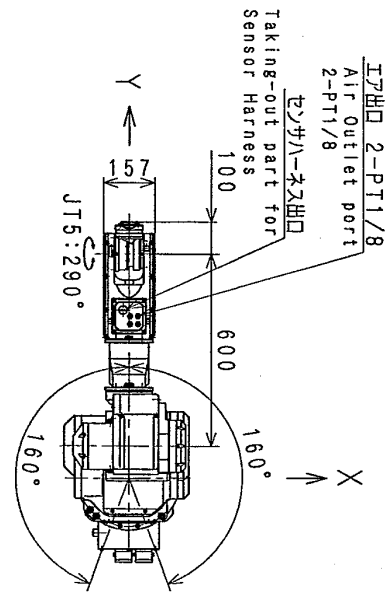
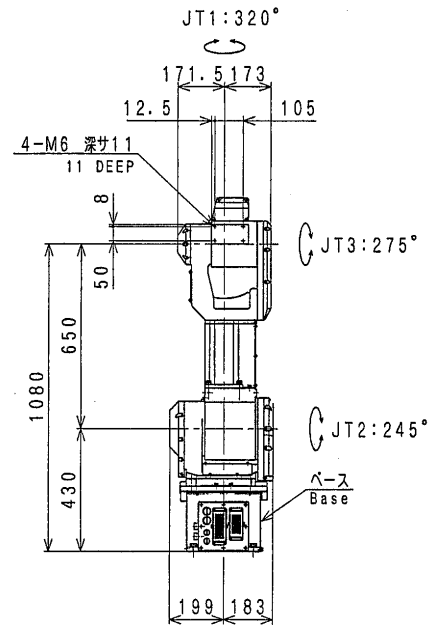
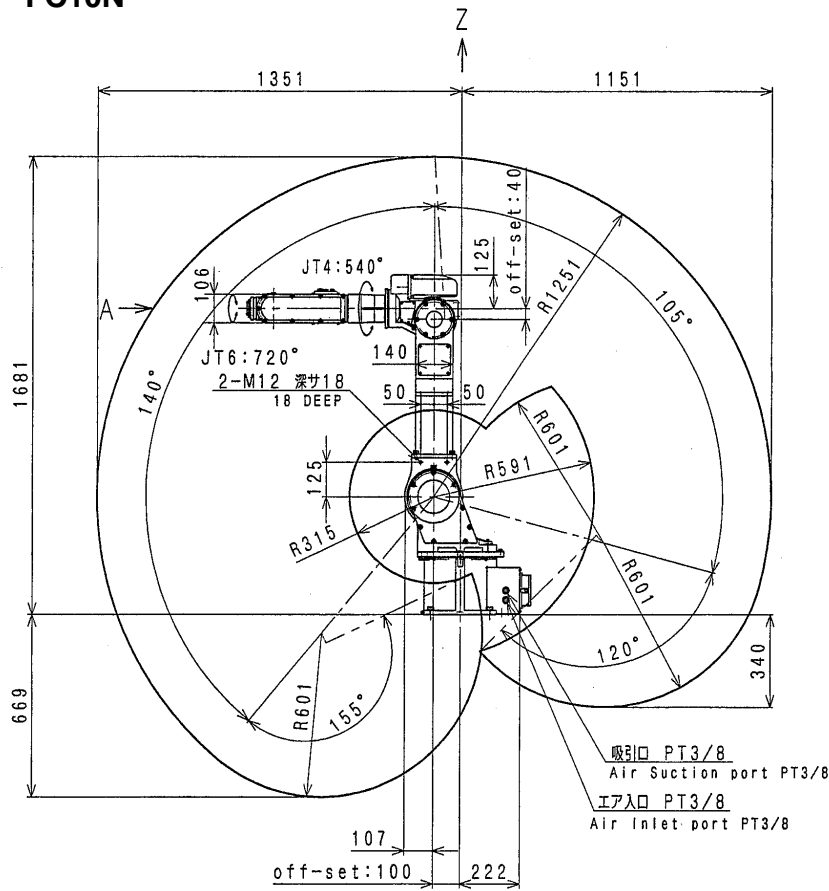

Type	Articulated Robot		
Degree of Freedom	6		
Motion Range and Maximum Speed	JT	Motion Range	Max. Speed
	1	±160°	200 °/s
	2	-105° to +140°	140 °/s
	3	-155° to +120°	200 °/s
	4	±270°	360 °/s
	5	±145°	360 °/s
Max. Payload	10 kg		
Wrist Load Capacity	JT	Torque	Moment of Inertia
	4	21.5 N·m	0.63 kg·m ²
	5	21.5 N·m	0.63 kg·m ²
	6	9.8 N·m	0.15 kg·m ²
Repeatability	±0.1 mm		
Mass	Approx. 170 kg		
Acoustic noise	< 70 db (A)*		

*measured condition

- installed on the plate rigidly fixed on the floor
- 2700 mm away from JT1 center

The noise level depends on the conditions.

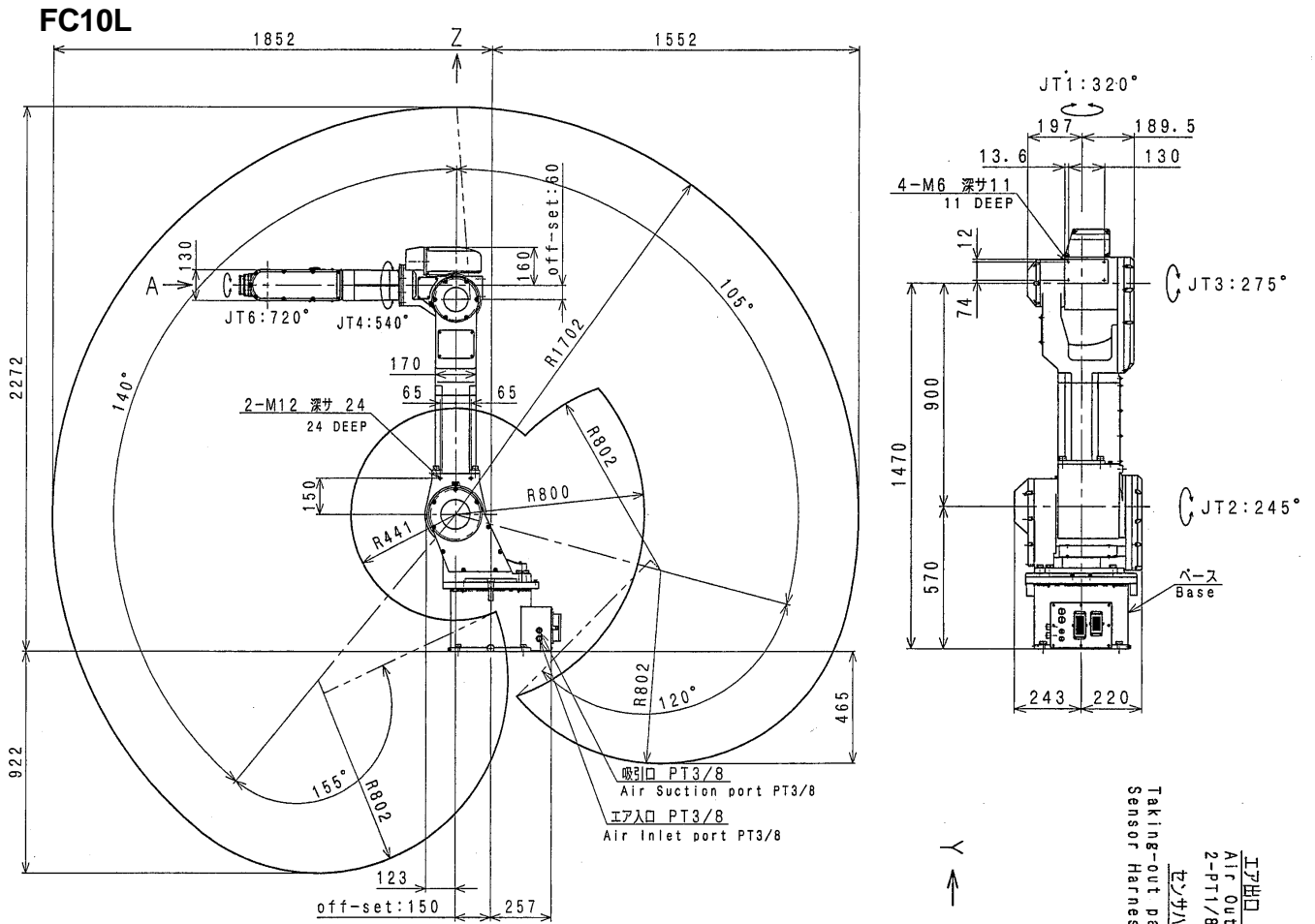

Type	Articulated Robot		
Degree of Freedom	6		
Motion Range and Maximum Speed	JT	Motion Range	Max. Speed
	1	±160°	160 %/s
	2	-105° to +140°	140 %/s
	3	-155° to +120°	160 %/s
	4	±270°	330 %/s
	5	±145°	330 %/s
6	±360°	500 %/s	
Max. Payload	10 kg		
Wrist Load Capacity	JT	Torque	Moment of Inertia
	4	21.5 N·m	0.63 kg·m ²
	5	21.5 N·m	0.63 kg·m ²
6	9.8 N·m	0.15 kg·m ²	
Repeatability	±0.1 mm		
Mass	Approx. 280 kg		
Acoustic noise	< 70 db (A)*		

*measured condition
 • installed on the plate rigidly fixed on the floor
 • 3200 mm away from JT1 center

[The noise level depends on the conditions.]

FC20N

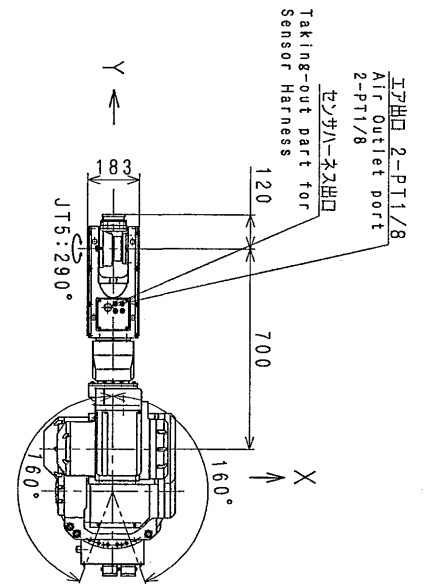
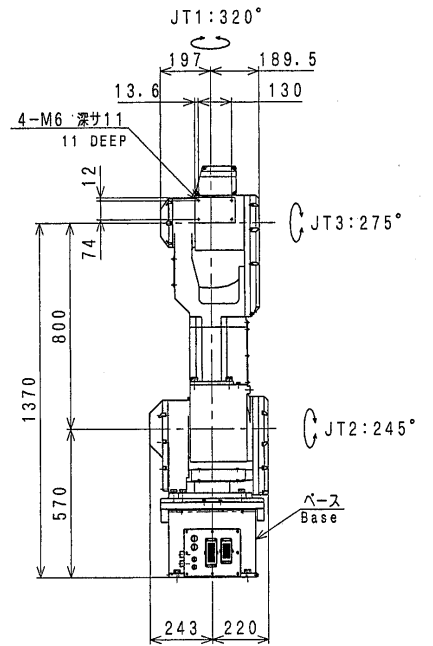
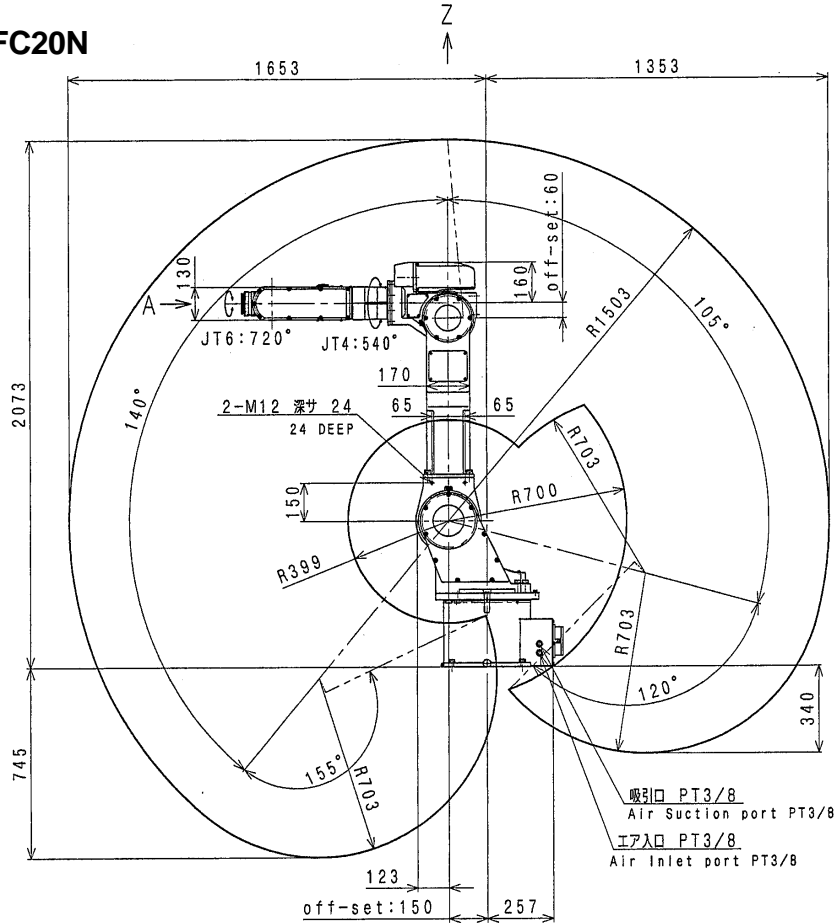

Type	Articulated Robot		
Degree of Freedom	6		
Motion Range and Maximum Speed	JT	Motion Range	Max. Speed
	1	±160°	160 °/s
	2	-105° to +140°	140 °/s
	3	-155° to +120°	160 °/s
	4	±270°	330 °/s
	5	±145°	330 °/s
Max. Payload	20 kg		
Wrist Load Capacity	JT	Torque	Moment of Inertia
	4	39.3 N·m	0.88 kg·m ²
	5	39.3 N·m	0.88 kg·m ²
6	19.6 N·m	0.25 kg·m ²	
Repeatability	±0.1 mm		
Mass	Approx. 280 kg		
Acoustic noise	< 70 db (A)*		

*measured condition
 • installed on the plate rigidly fixed on the floor
 • 2900 mm away from JT1 center

[The noise level depends on the conditions.]

FC30N

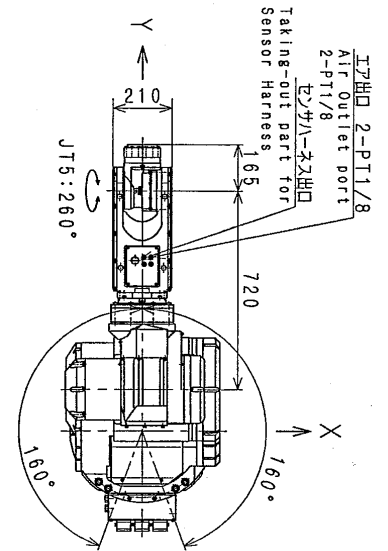
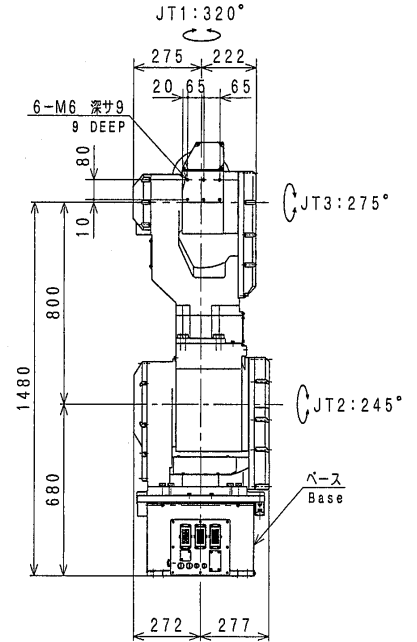
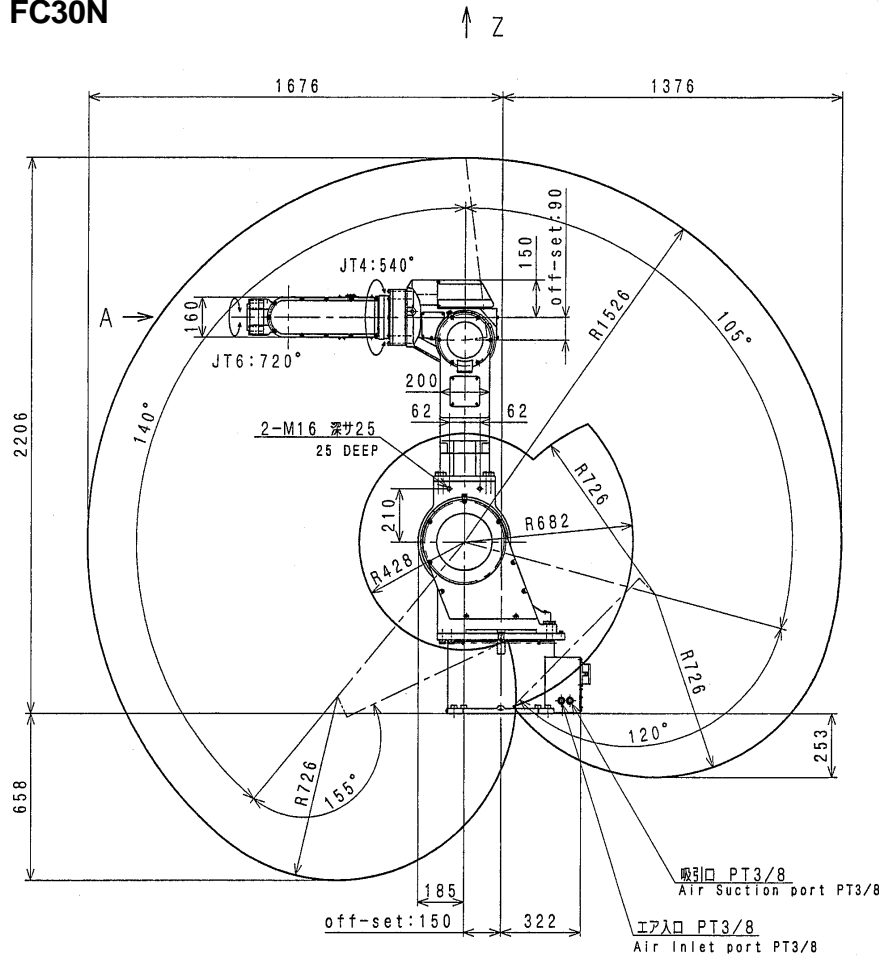

Type	Articulated Robot		
Degree of Freedom	6		
Motion Range and Maximum Speed	JT	Motion Range	Max. Speed
	1	±160°	160 °/s
	2	-105° to +140°	140 °/s
	3	-155° to +120°	160 °/s
	4	±270°	240 °/s
	5	±130°	240 °/s
6	±360°	340 °/s	
Max. Payload	30 kg		
Wrist Load Capacity	JT	Torque	Moment of Inertia
	4	176.4 N·m	7.2 kg·m ²
	5	176.4 N·m	7.2 kg·m ²
6	98.0 N·m	3.3 kg·m ²	
Repeatability	±0.15 mm		
Mass	Approx. 575 kg		
Acoustic noise	< 70 db (A)*		

- *measured condition
- installed on the plate rigidly fixed on the floor
 - 3700 mm away from JT1 center

The noise level depends on the conditions.

FC30L

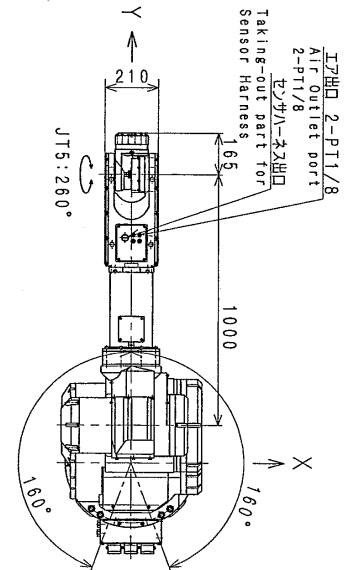
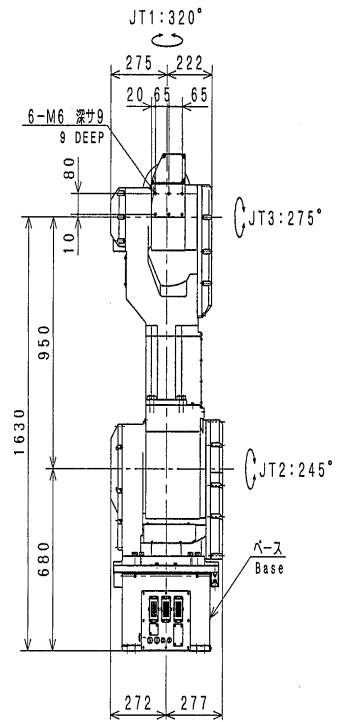
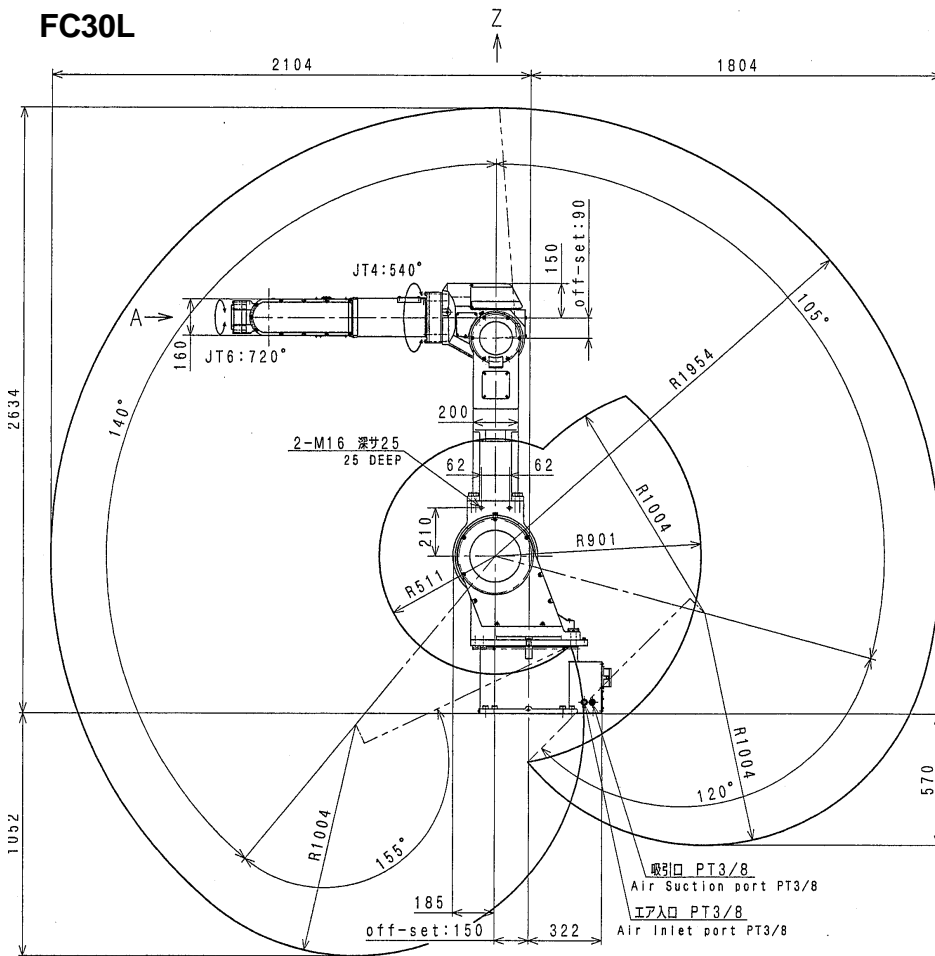

Type	Articulated Robot		
Degree of Freedom	6		
	JT	Motion Range	Max. Speed
	1	±160°	160 %/s
	2	-105° to +140°	140 %/s
	3	-155° to +120°	160 %/s
	4	±270°	240 %/s
	5	±130°	240 %/s
6	±360°	340 %/s	
Max. Payload	30 kg		
	JT	Torque	Moment of Inertia
	4	176.4 N·m	7.2 kg·m ²
	5	176.4 N·m	7.2 kg·m ²
6	98.0 N·m	3.3 kg·m ²	
Repeatability	±0.15 mm		
Mass	Approx. 585 kg		
Acoustic noise	< 70 db (A)*		

*measured condition
 • installed on the plate rigidly fixed on the floor
 • 4100 mm away from JT1 center

The noise level depends on the conditions.

FC45N

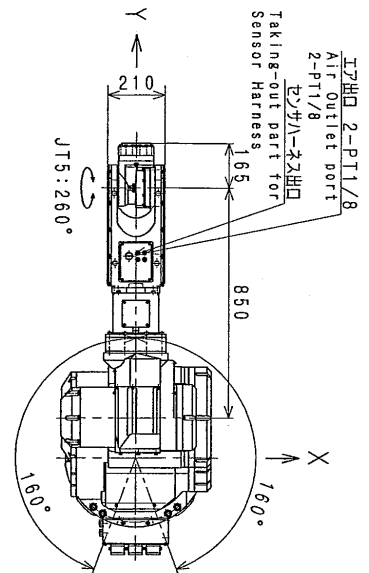
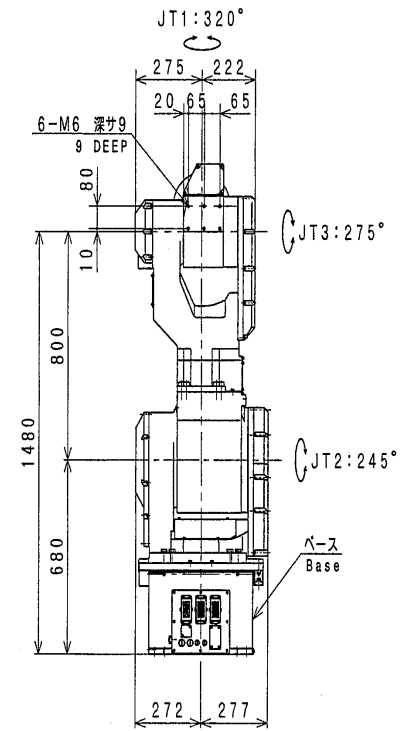
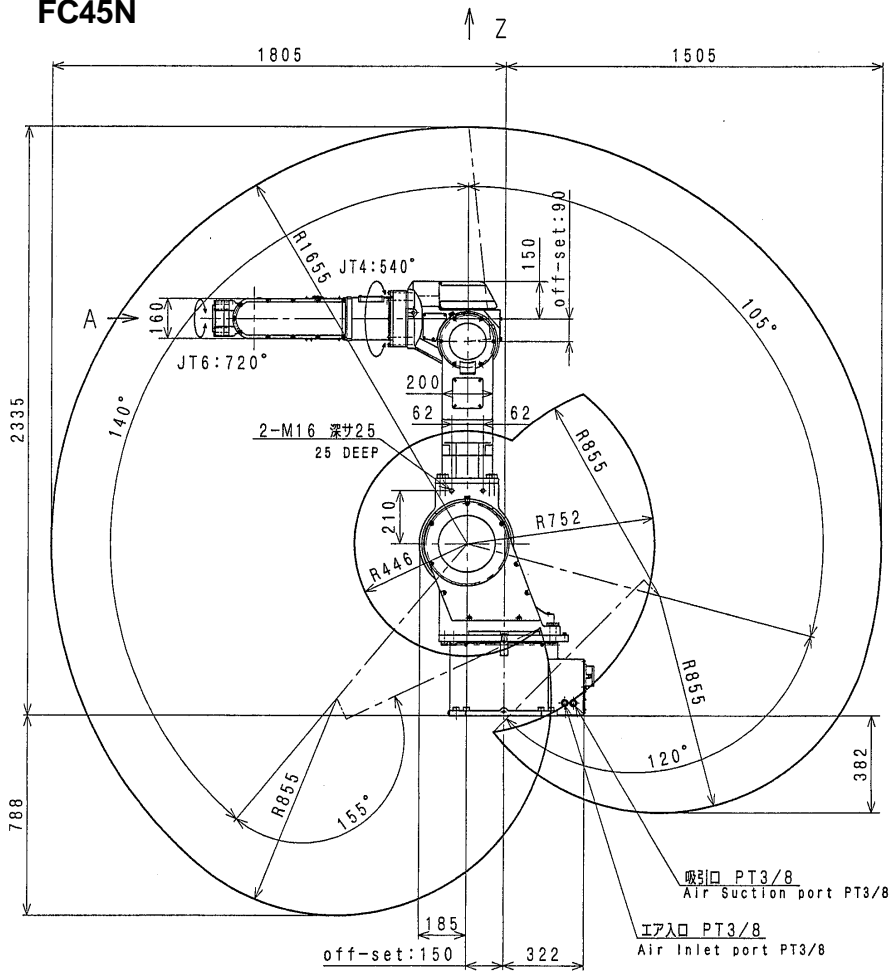

Type	Articulated Robot		
Degree of Freedom	6		
Motion Range and Maximum Speed	JT	Motion Range	Max. Speed
	1	±160°	160 °/s
	2	-105° to +140°	140 °/s
	3	-155° to +120°	160 °/s
	4	±270°	240 °/s
	5	±130°	240 °/s
6	±360°	340 °/s	
Max. Payload	45 kg		
Wrist Load Capacity	JT	Torque	Moment of Inertia
	4	176.4 N·m	10.8 kg·m ²
	5	176.4 N·m	10.8 kg·m ²
6	98.0 N·m	5.0 kg·m ²	
Repeatability	±0.15 mm		
Mass	Approx. 580 kg		
Acoustic noise	< 70 db (A)*		

- *measured condition
- installed on the plate rigidly fixed on the floor
 - 3400 mm away from JT1 center

The noise level depends on the conditions.

FC60L

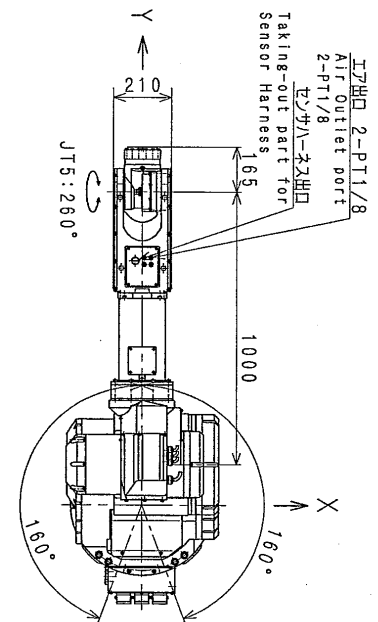
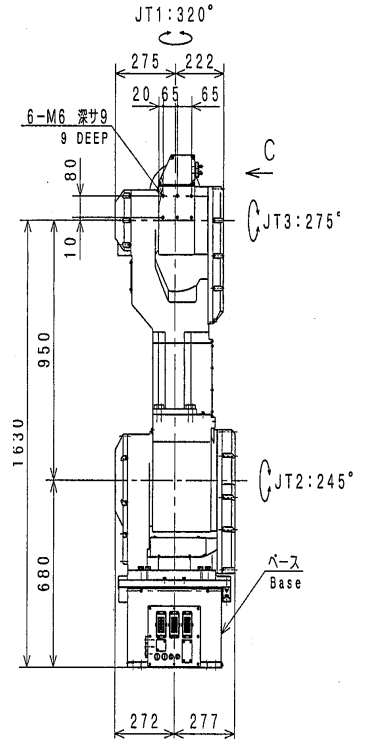
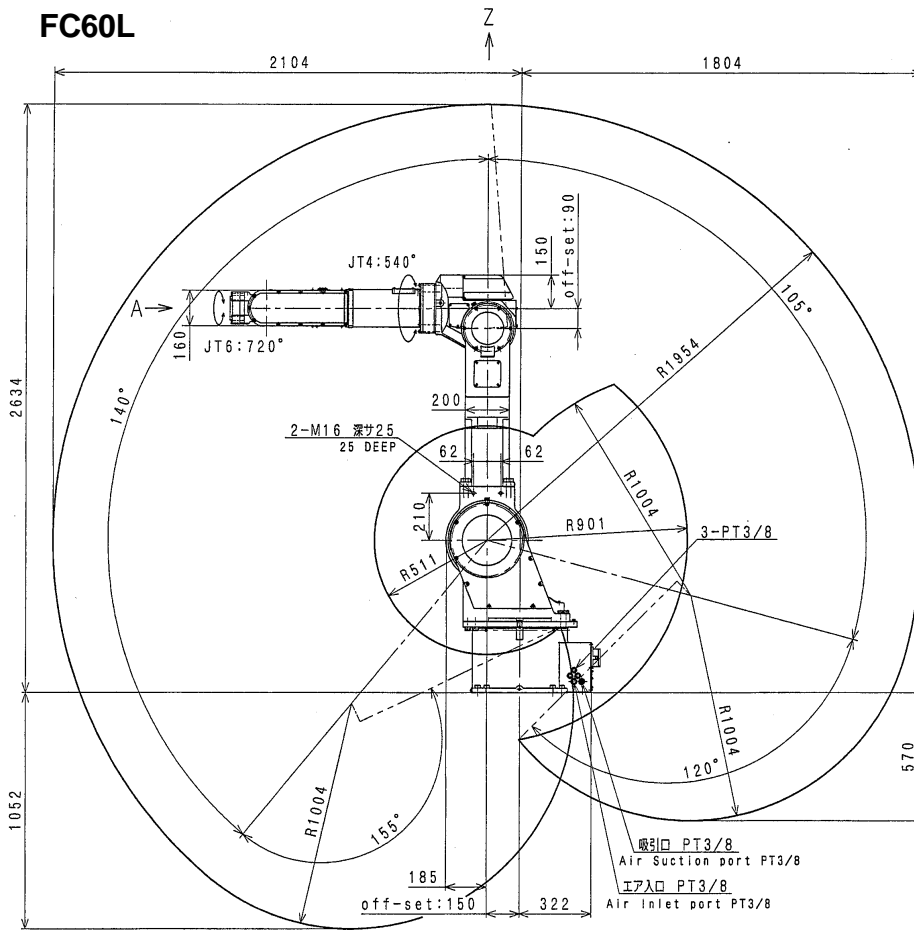

Type	Articulated Robot		
Degree of Freedom	6		
Motion Range and Maximum Speed	JT	Motion Range	Max. Speed
	1	±160°	160 °/s
	2	-105° to +140°	100 °/s
	3	-155° to +120°	110 °/s
	4	±270°	180 °/s
	5	±130°	175 °/s
Max. Payload	60 kg		
Wrist Load Capacity	JT	Torque	Moment of Inertia
	4	235.2 N·m	24.8 kg·m ²
	5	235.2 N·m	24.8 kg·m ²
	6	130.3 N·m	6.7 kg·m ²
Repeatability	±0.15 mm		
Mass	Approx. 585 kg		
Acoustic noise	< 70 db (A)*		

- *measured condition
- installed on the plate rigidly fixed on the floor
 - 3700 mm away from JT1 center

The noise level depends on the conditions.

FD50N

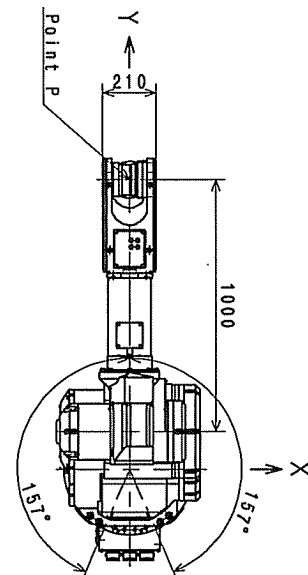
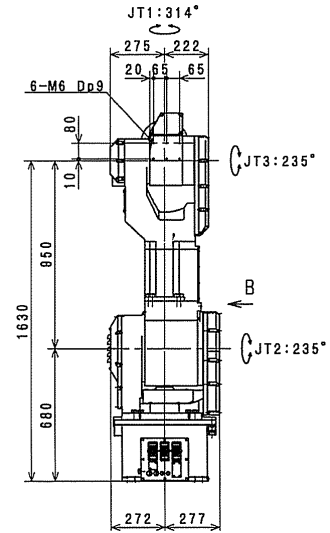
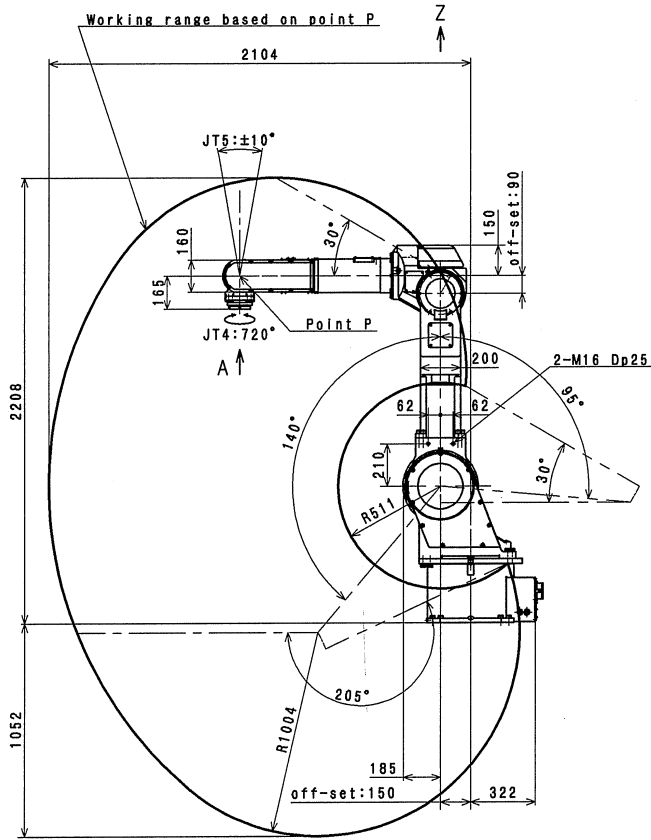

Type	Articulated Robot		
Degree of Freedom	6		
Motion Range and Maximum Speed	JT	Motion Range	Max. Speed
	1	±157°	180 °/s
	2	-95° to +140°	150 °/s
	3	-205° to +30°	180 °/s
	4	±360°	350 °/s
	5	±10°*	-
	*+/-10° from vertical downward posture		
Max. Payload	50 kg		
Wrist Load Capacity	JT	Torque	Moment of Inertia
	4	-	4.4 kg·m ²
Repeatability	±0.15 mm		
Mass	Approx. 585 kg		
Acoustic noise	< 70 db (A)*		

- *measured condition
- installed on the plate rigidly fixed on the floor
 - 4100 mm away from JT1 center

The noise level depends on the conditions.

4.0 ROBOT TRANSPORTATION METHOD - WIRE SLING

According to the figure, hoist up the robot by double wire slings attached to both sides of the robot. (Use this same method for hoisting up the robot stand and/or the base plate.)

⚠ CAUTION

When hoisting up the robot, be careful as robot may lean forward/backward depending on robot posture and installation condition of the options. If the robot is hoisted up in an inclined posture, it may swing, or the wire may interfere with the harness, piping etc., or it may be damaged from interfering with surrounding objects. Protect the robot with wear plates, etc. if wires interfere with a part of the robot. Remove the hoisting tool once the transportation of robot is completed.

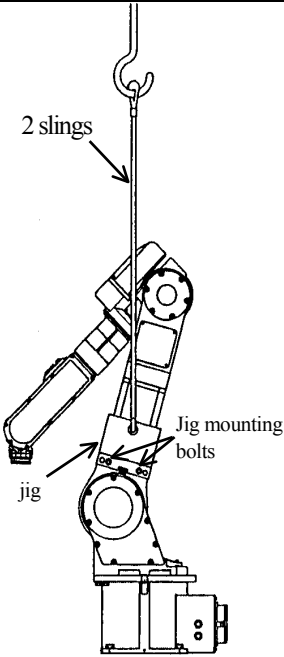
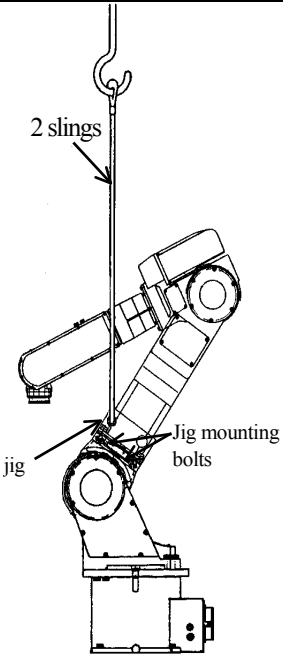
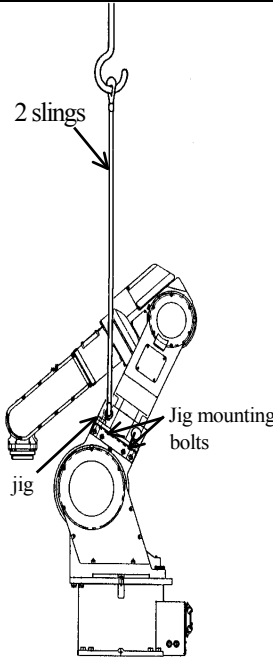
Model		FS06N, FS06L, FA06N, FA06E, FC06N, FC06L, FS10C, FS10N, FS10E, FA10N, FC10N	FS10L, FA10L, FC10L, FS20C, FS20N, FA20N, FC20N	FS10X, FS20X, FS30N, FS30L, FA30L, FC30N, FC30L, FS45C, FS45N, FC45N, FD50N, FS60L, FC60L
Posture				
Hoisted up posture	JT1	0°	0°	0°
	JT2	-10°	-50°	-30°
	JT3	-150°	-150°	-155° (-35°)
	JT4	0°	0°	0°
	JT5	-40°	-80°	-55° (0°)
	JT6	0°	0°	0°
Jig mounting bolts		M12-20L×4	M12-25L×4	M16-30L×4

() : for FD50N

5.0 INSTALLING DIMENSIONS OF BASE SECTION

When installing the base section, fix it by means of high tension bolts utilizing the bolt holes.

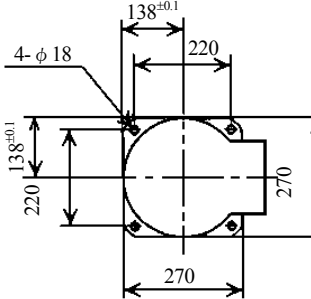
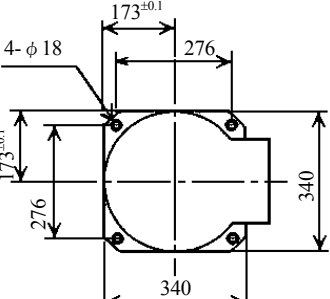
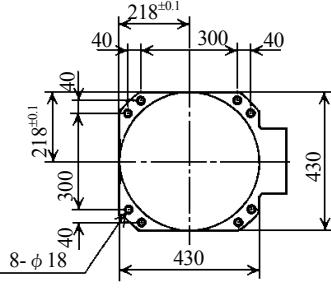
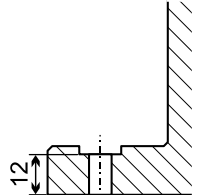
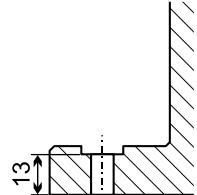
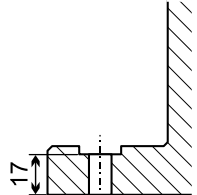
Model	FS06N, FS06L, FA06N, FA06E, FC06N, FC06L, FS10C, FS10N, FS10E, FA10N, FC10N	FS10L, FA10L, FC10L, FS20C, FS20N, FA20N, FC20N	FS10X, FS20X, FS30N, FS30L, FA30L, FC30N, FC30L, FS45C, FS45N, FC45N, FD50N, FS60L, FC60L
Dimensions of base section			
Cross-section of base installation			
Bolt hole	4-φ18	4-φ18	8-φ18
High tension bolt	4-M16 Material: SCM435 Strength class: 10.9 min.	4-M16 Material: SCM435 Strength class: 10.9 min	8-M16 Material: SCM435 Strength class: 10.9 min
Tightening torque	235.2 N·m	235.2 N·m	235.2 N·m
Inclination	Within ±5°	Within ±5°	Within ±5°

6.0 DIMENSIONS OF ROBOT STAND

When installing the robot stand, fix it by means of high tension bolts utilizing the bolt holes.

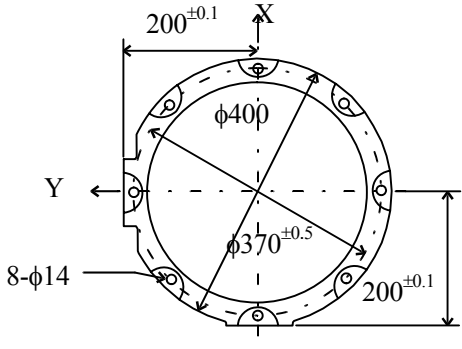
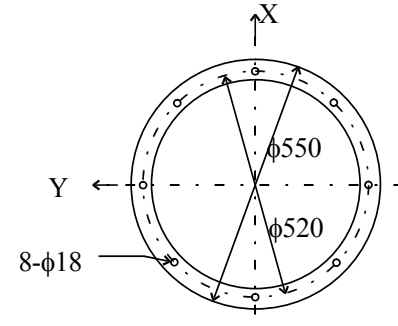
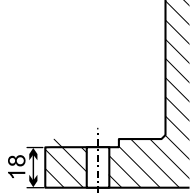
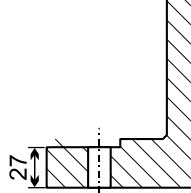
Model	FS06N, FS06L, FA06N, FA06E, FC06N, FC06L, FS10C, FS10N, FS10E, FS10L, FA10N, FA10L, FC10N, FC10L, FS20C, FS20N, FA20N, FC20N	FS10X, FS20X, FS30N, FS30L, FA30L, FC30N, FC30L, FS45C, FS45N, FC45N, FD50N, FS60N, FC60L
Dimensions of base section		
Cross-section of base installation		
Bolt hole	8-φ14	8-φ18
High tension bolt	8-M12 Material: SCM435 Strength class: 10.9 min	8-M16 Material: SCM435 Strength class: 10.9 min
Tightening torque	98 N·m	235 N·m
Inclination	Within ±5°	Within ±5°

7.0 INSTALLATION METHOD

7.1 WHEN INSTALLING THE BASE DIRECTLY ON THE FLOOR

As in the below figure, bury steel plate (28 mm Min. thick) in the concrete floor or fix it with anchors. The steel plate should be fixed firmly enough to endure the reaction forces produced by the robot.

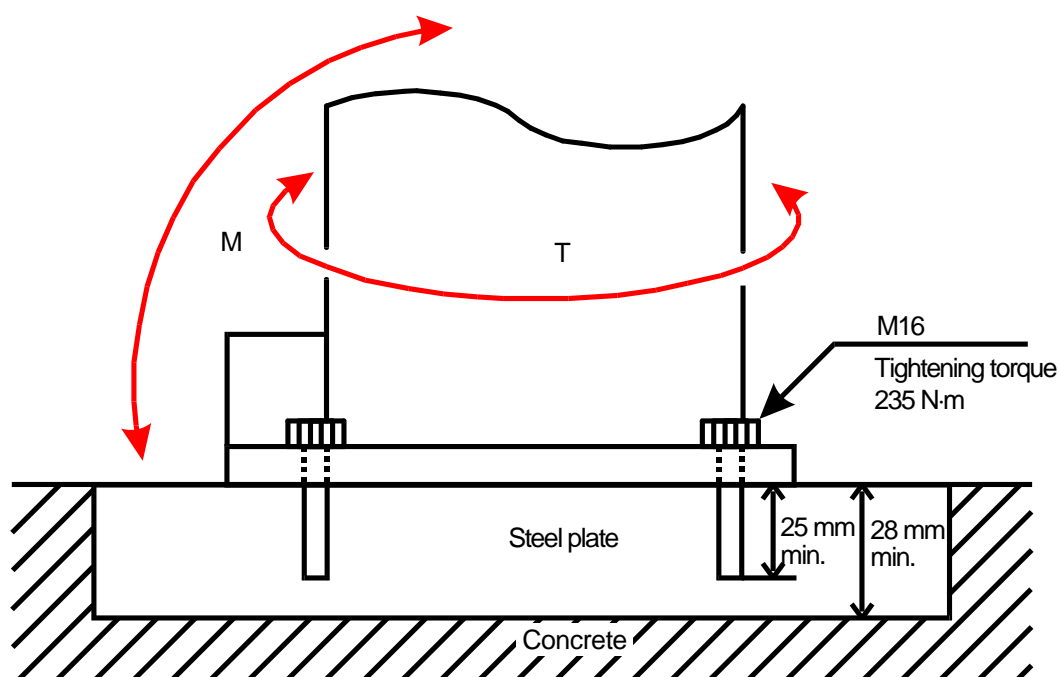

Model	FS06N, FS06L, FA06N, FA06E, FC06N, FC06L, FS10C, FS10N, FS10E, FA10N, FC10N	FS10L, FA10L, FC10L, FS20C, FS20N, FA20N, FC20N	FS10X, FS20X, FS30N, FS30L, FA30L, FC30N, FC30L, FS45C, FS45N, FC45N, FD50N, FS60L, FC60L
M (Inversion moment)	1578 N·m	2822 N·m	8310 N·m
T (Rotating torque)	833 N·m	1519 N·m	5096 N·m

7.2 WHEN INSTALLING THE ROBOT STAND ON THE FLOOR

In this case, the installing procedures are practically the same as the procedure for installing the robot base directly on the floor.

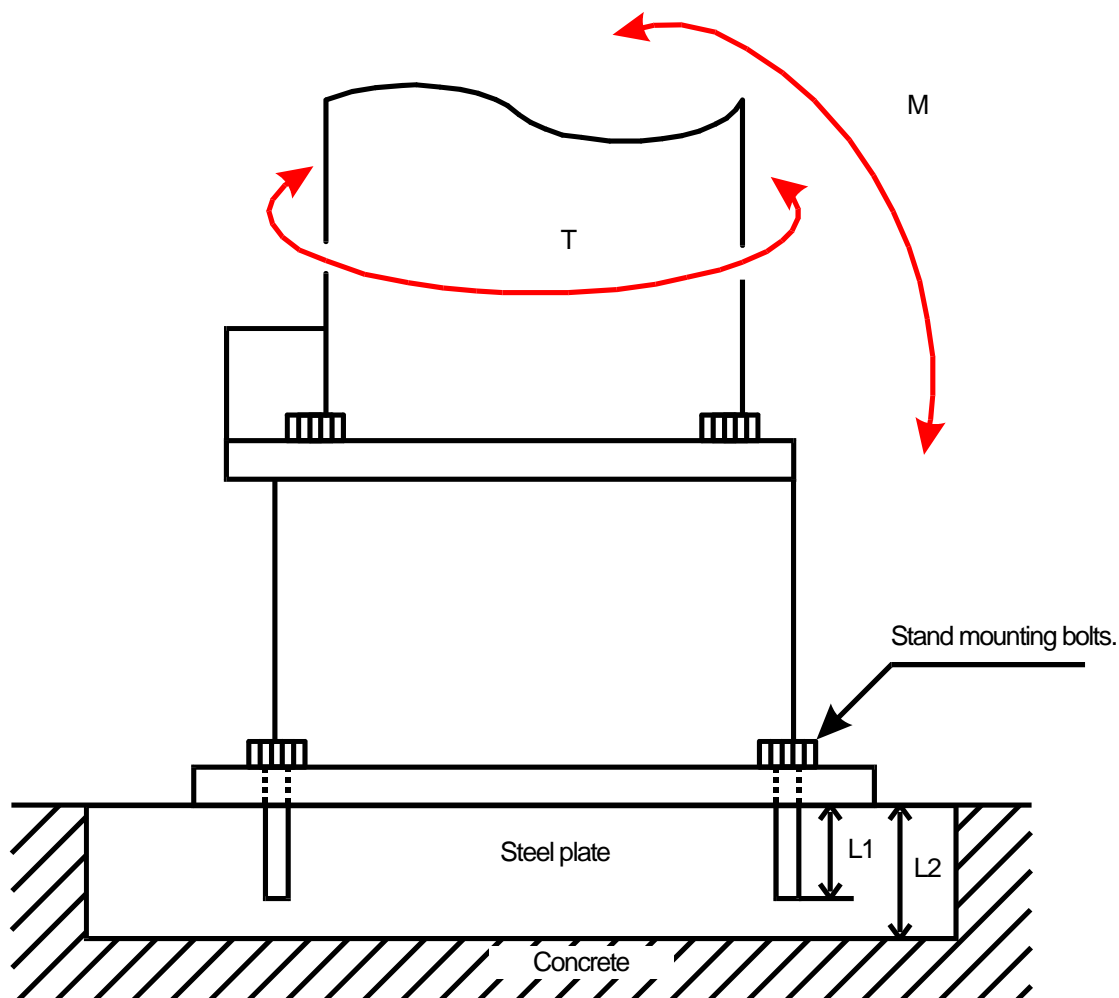

Model	FS06N, FS06L, FA06N, FA06E, FC06N, FC06L, FS10C, FS10N, FS10E, FS10L, FA10N, FA10L, FC10N, FC10L, FS20C, FS20N, FA20N, FC20N	FS10X, FS20X, FS30N, FS30L, FA30L, FC30N, FC30L, FS45C, FS45N, FC45N, FD50N, FS60L, FC60L
Stand mounting bolts	8-M12	8-M16
Tightening torque	98 N·m	235 N·m
L1	18 mm min.	25 mm min.
L2	20 mm min.	28 mm min.

Reaction forces are received from the robot in the same way as when the base is installed directly on the floor.

7.3 WHEN THE ROBOT BASE PLATE IS INSTALLED ON THE FLOOR

Install the plate using 4 of $\phi 20$ or $\phi 22$ bolt holes (PCD800). Install the base plate on a concrete floor or steel plate floor. Reaction forces are received from the robot in the same way as when the base is installed directly on the floor.

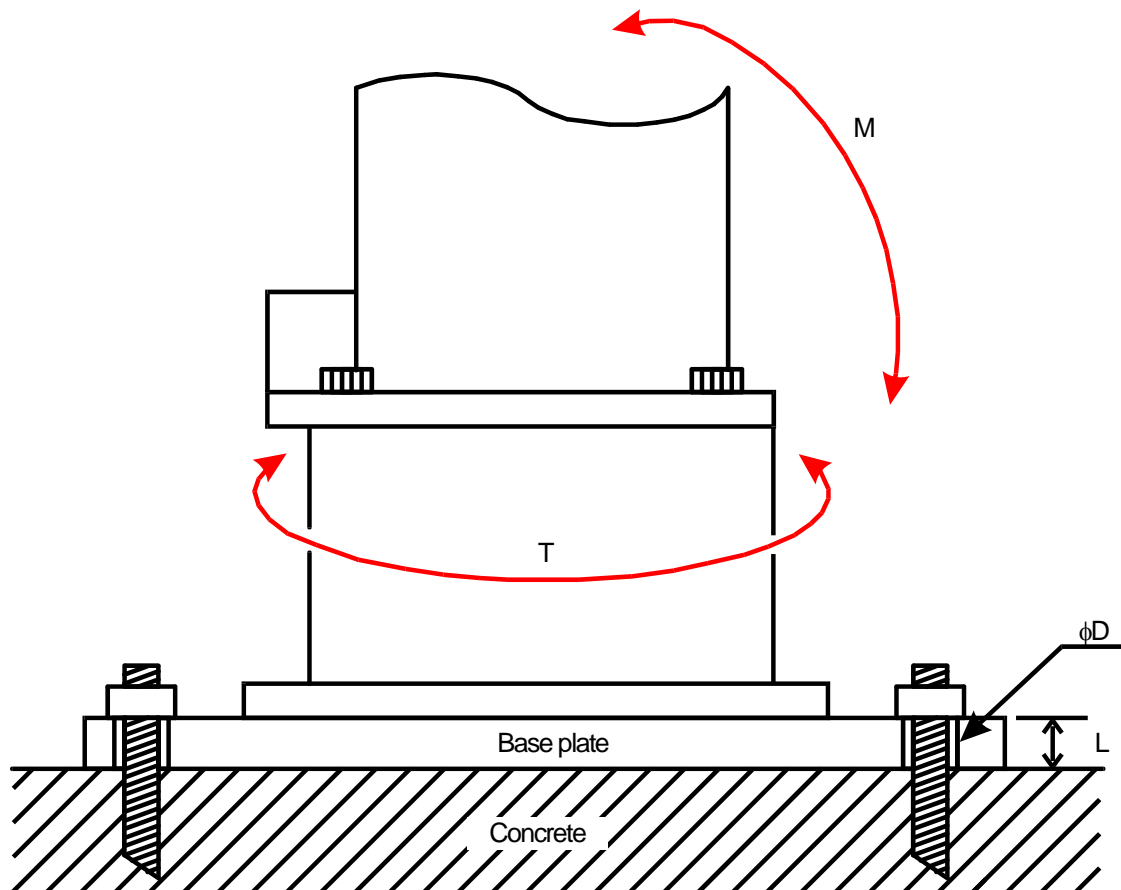

Model	FS06N, FS06L, FA06N, FA06E, FC06N, FC06L, FS10C, FS10N, FS10E, FS10L, FA10N, FA10L, FC10N, FC10L, FS20C, FS20N, FA20N, FC20N	FS10X, FS20X, FS30N, FS30L, FA30L, FC30N, FC30L, FS45C, FS45N, FC45N, FD50N, FS60L, FC60L
ϕD	$\phi 20$ mm	$\phi 22$ mm
L	20 mm	25 mm

8.0 MOUNTING OF TOOLS

! **WARNING**

Prior to installing tools on the robot, turn OFF the main power switch and the external power switch. Display signs indicating clearly “Inspection and Maintenance in Progress”, and lockout/tagout the external power switch to prevent personnel from accidentally turning ON the power.

8.1 DIMENSIONS OF WRIST END

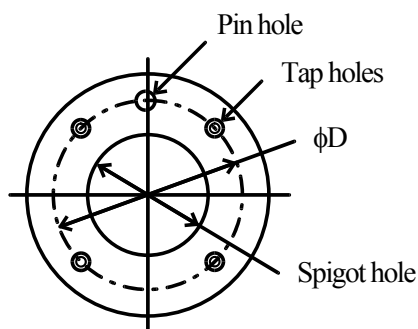

In the robot arm end section, a flange is provided through which the hand, gun, or other tools are installed. Screw the fixing bolts, into the tap holes on the circumference of ϕD on the flange, referring to the figure on the left. Moreover, for positioning of hand and gun by utilizing the pin hole and the spigot hole.

8.2 SPECIFICATION OF FIXING BOLT

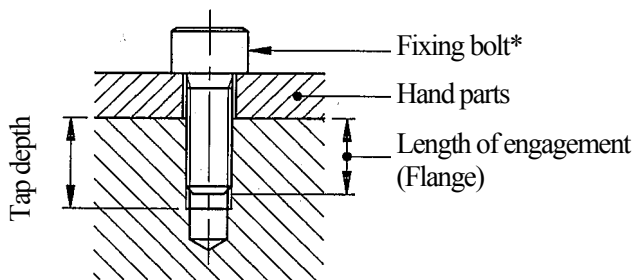

Select fixing bolts of the proper length to fit the specified screwing depth of the tap holes on the tool-mounting flange. The fixing bolt should be a high tension spec. and tightened at the specified torque.

*Note: Screw up the fixing bolt at the tightening torque specified below.

! **CAUTION**

If the screwing depth has exceeded the specified depth, the fixing bolt might bottom out, and the tool will not be fixed securely.

Model	FS06N, FS06L, FA06N, FA06E, FC06N, FC06L, FS10C, FS10N, FS10E, FS10X, FA10N, FC10N	FS10L, FA10L, FC10L, FS20C, FS20N, FS20X, FA20N, FC20N	FS30N, FS30L, FA30L, FC30N, FC30L, FS45C, FS45N, FC45N, FD50N, FS60L, FC60L
Tap holes	4-M6	4-M6	6-M8
φD	φ40	φ63	φ80
Pin hole	φ6H7 Deep6	φ6H7 Deep6	φ8H7 Deep8
Spigot hole	φ25H7 Deep6	φ40H7 Deep6	φ50H7 Deep6
Tap depth	8 mm	8 mm	14 mm
Screwing depth	6~7 mm	6~7 mm	8~12 mm
High tension bolt	SCM435, 10.9 min	SCM435, 10.9 min	SCM435, 10.9 min
Tightening torque	11.76 N·m	11.76 N·m	29.40 N·m

8.3 LOAD CAPACITY

The mass capacity of robot is specified for each model and all includes the mass such hand, gun, etc. Also, the load capacity of wrist section is provided with specified conditions. Strictly observe the following restrictions applied to the load torque and load moment of inertia on wrist axes (JT4, JT5, JT6).

⚠ CAUTION

Using the robot beyond its specified load capacity may result in degradation of movement performance and shortening of machine service life. The specified range includes the mass of hand, tool changer, spot weld gun, etc. If the load exceeds load capacity, first contact Kawasaki without fail.

For FS, FA and FC series

The load torque and the moment of inertia can be calculated by the expression below:

Calculation Expression

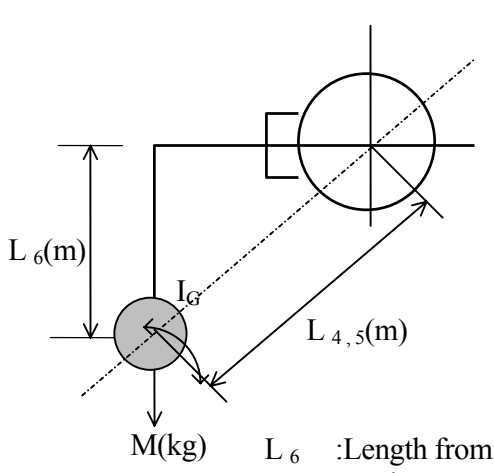

L_6 :Length from JT6 axis rotation center to load center of gravity.
 $L_{4,5}$:Length from JT4(5) axis rotation center to load center of gravity.

Load Mass : $M \leq M_{max}(\text{kg})$
(including hand)

Load Torque : $T=9.8 \cdot M \cdot L(\text{N} \cdot \text{m})$

Load Moment of Inertia: $I=M \cdot L^2+I_G(\text{kg} \cdot \text{m}^2)$

Mmax: Rated Load Mass (For example)

FS06 ...Mmax. :6 kg
 FS10 ...Mmax. :10 kg
 FS20 ...Mmax. :20 kg
 FS30 ...Mmax. :30 kg
 FS45 ...Mmax. :45 kg
 FS60 ...Mmax. :60 kg

If calculation of load is made by dividing the load section into multiple parts, such as hand sections and workpiece sections, use the total value to calculate load torque and moment of inertia.

The load of the robot wrist section must conform with the following restriction:

1. The load mass including hand mass should be less than the following value.
FS06: 6 kg, FS10: 10 kg, FS20: 20 kg, FS30: 30 kg, FS45: 45 kg, FS60: 60 kg
2. The load torque and the moment of inertia around Joints (JT4, JT5, JT6) should be within the following restriction depending on the axis:

FS06N, FS06L, FA06N, FA06E, FC06N, FC06L

Load moment of inertia

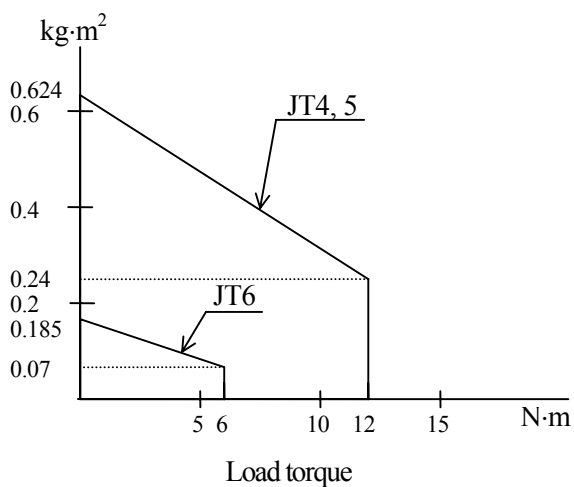

FS10C, FS10N, FS10E, FS10L, FA10N, FA10L, FS10X, FC10N, FC10L

Load moment of inertia

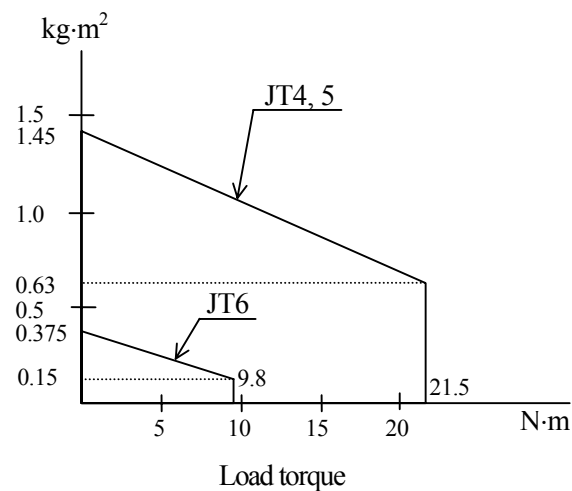

FS20C, FS20N, FS20X, FA20N, FC20N

Load moment of inertia

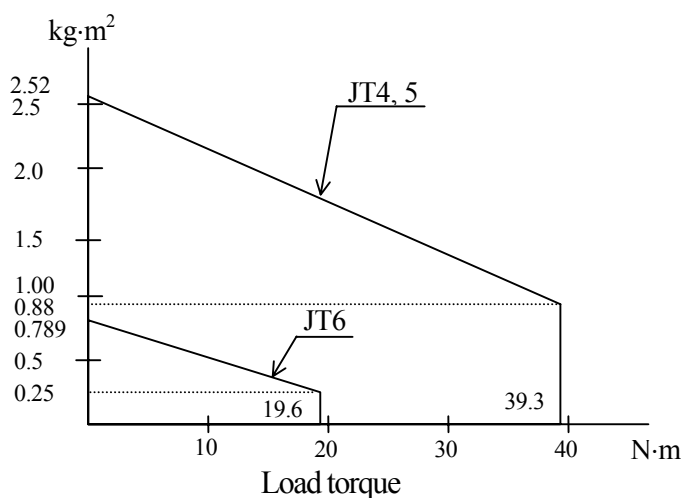

FS30N, FS30L, FA30L, FC30N, FC30L

FS45C, FS45N, FC45N

Load moment of inertia

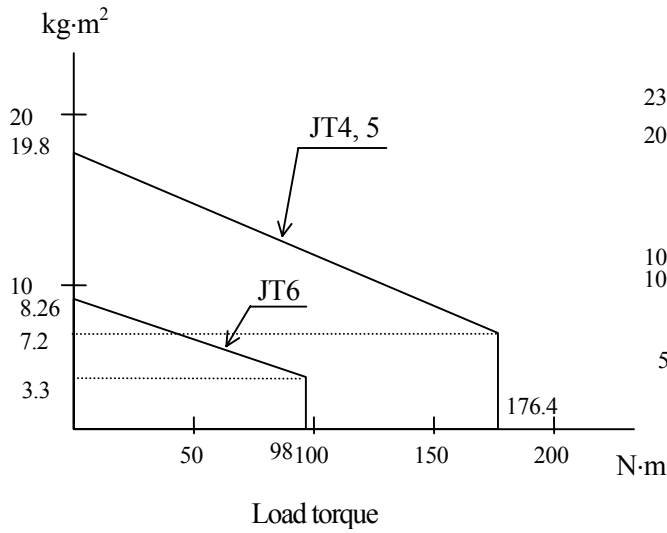

Load moment of inertia

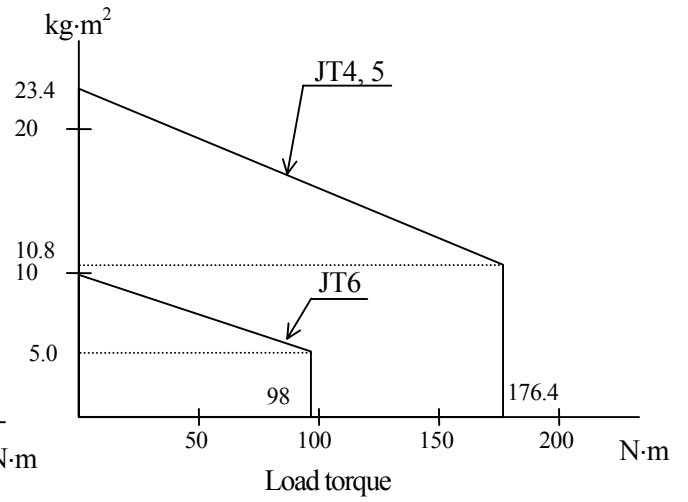

FS60L, FC60L

Load moment of inertia

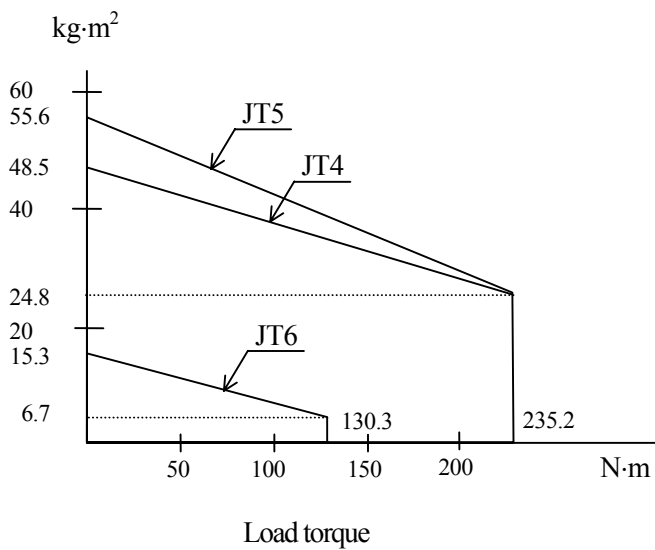

For FD50N

The load torque and the moment of inertia in wrist section should be calculated by expressions below.

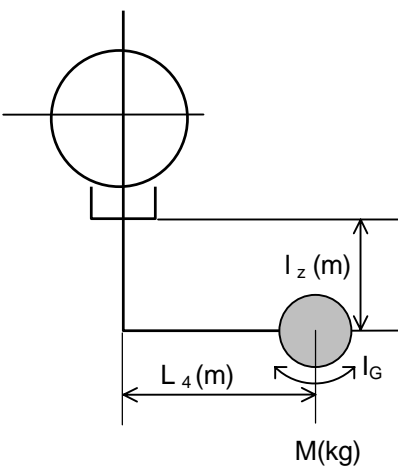
Calculation Expression	
	<p>Load Mass (including hand): $M \leq M_{max.} (kg)$</p> <p>Load Torque: not specified</p> <p>Load Moment of Inertia: $I = M \cdot L^2 + I_G (kg \cdot m^2) \leq I_{max} (kg \cdot m^2)$</p> <p>Center position of gravity (L_4, I_z): See diagrams below.</p> <p>$M_{max.}$: Rated Load Mass 50 (kg)</p> <p>$I_{max.}$: Rated Load Moment of inertia $4.4 (kg \cdot m^2)$</p> <p>I_G: Moment of inertia around center of gravity. ($kg \cdot m^2$)</p> <p>I_z: Length from flange to load center of gravity. (m)</p> <p>L_4: Length from JT4 axis rotating center to load center of gravity. (m)</p>
	<p>When calculating the load by dividing it into sections (for example, hand section, work section, etc.), evaluate the inertia moment from the sum of all the sections.</p>

Strictly observe the following restrictions applied to wrist sections.

1. The allowable load mass including hand should be less than the $M_{max.}$ above.
2. Restrictions are applied to the load moment of inertia in wrist section (JT4). The load moment of inertia should be below $4.4 kg \cdot m^2$.
3. Restrictions are applied to the center of gravity. The center should be positioned within the allowable range shown below. There are two diagrams; when moving with JT5 facing vertically down (0°) and when moving with JT5 tilted (within $\pm 10^\circ$ of vertical down).

Diagram of load on wrist section (JT5:0°)

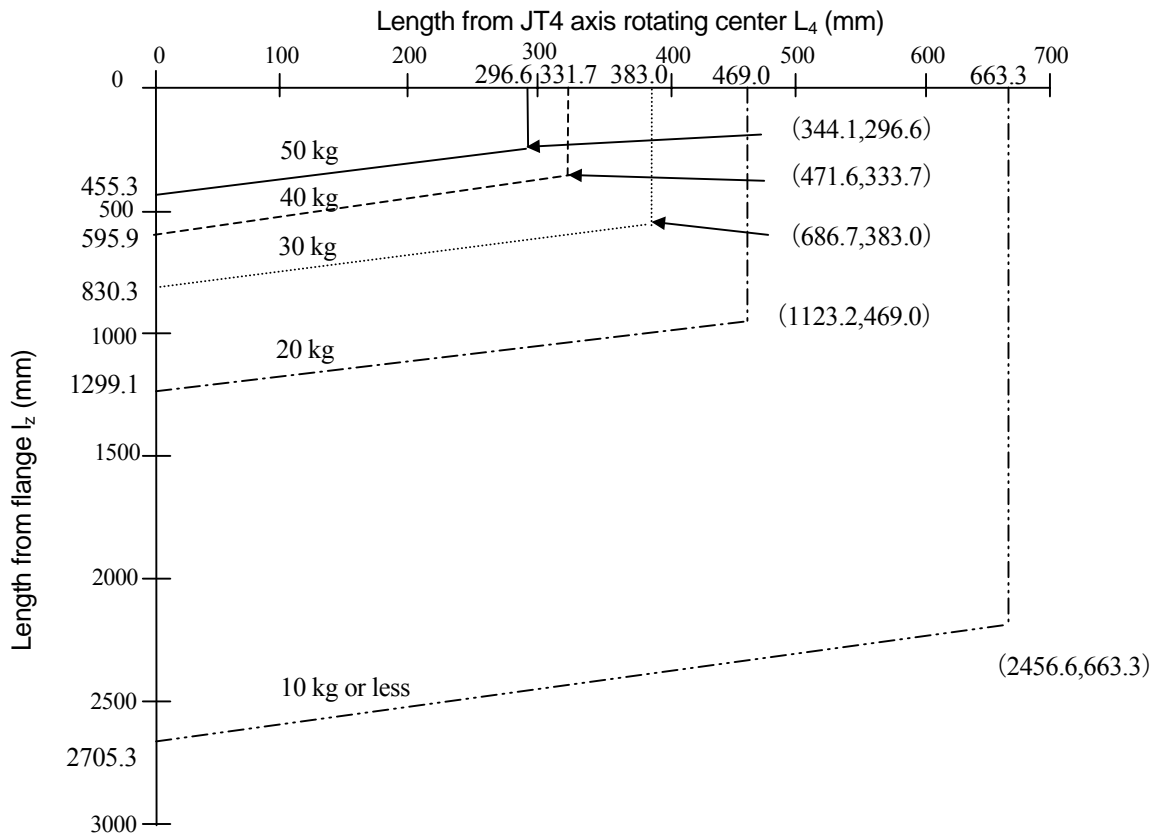
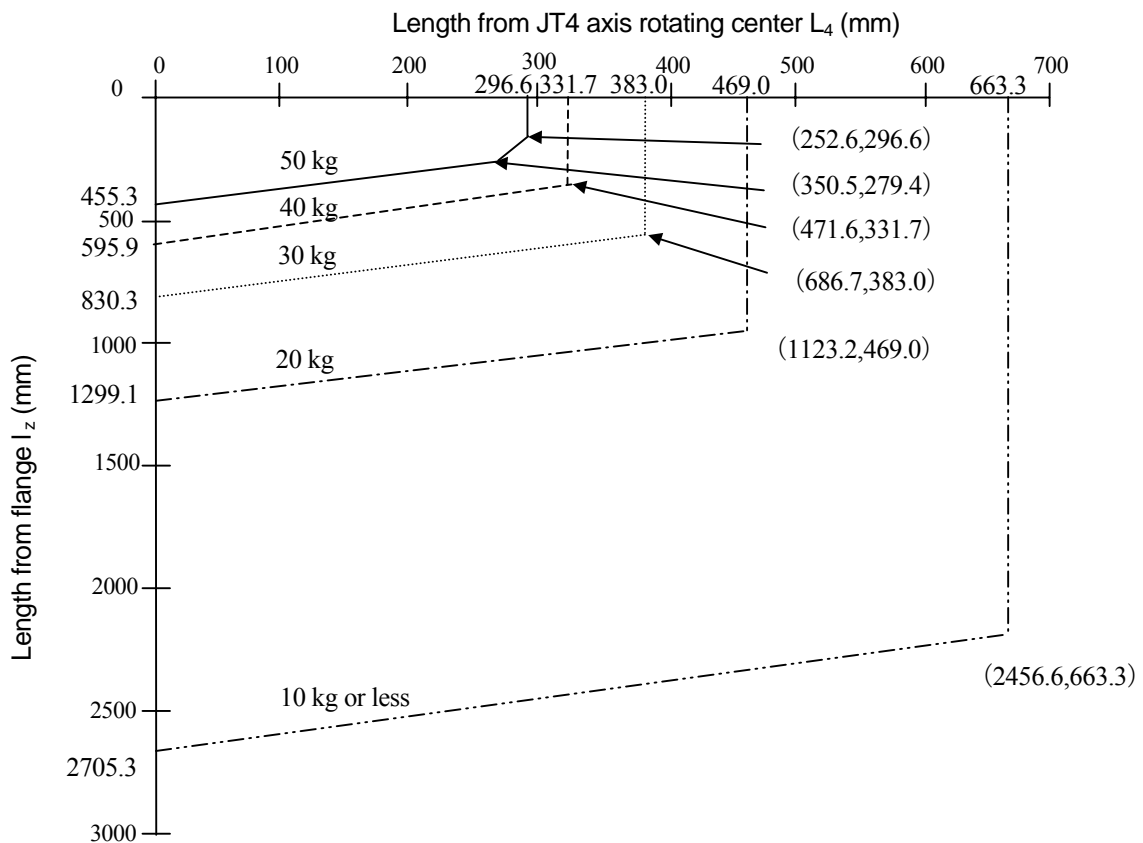

Diagram of load on wrist section (JT5: within +/-10°)



9.0 CONNECTION OF AIR SYSTEM

9.1 AIR PIPING ARRANGEMENT

F Series houses air piping and valves for driving the tool on the robot arm. The valves can be turned ON/OFF by the Multi Function Panel (Teach Pendant) without using an interlock.

FS06N, FS06L, FS10C, FS10N, FS10E, FS10L, FS20C, FS20N

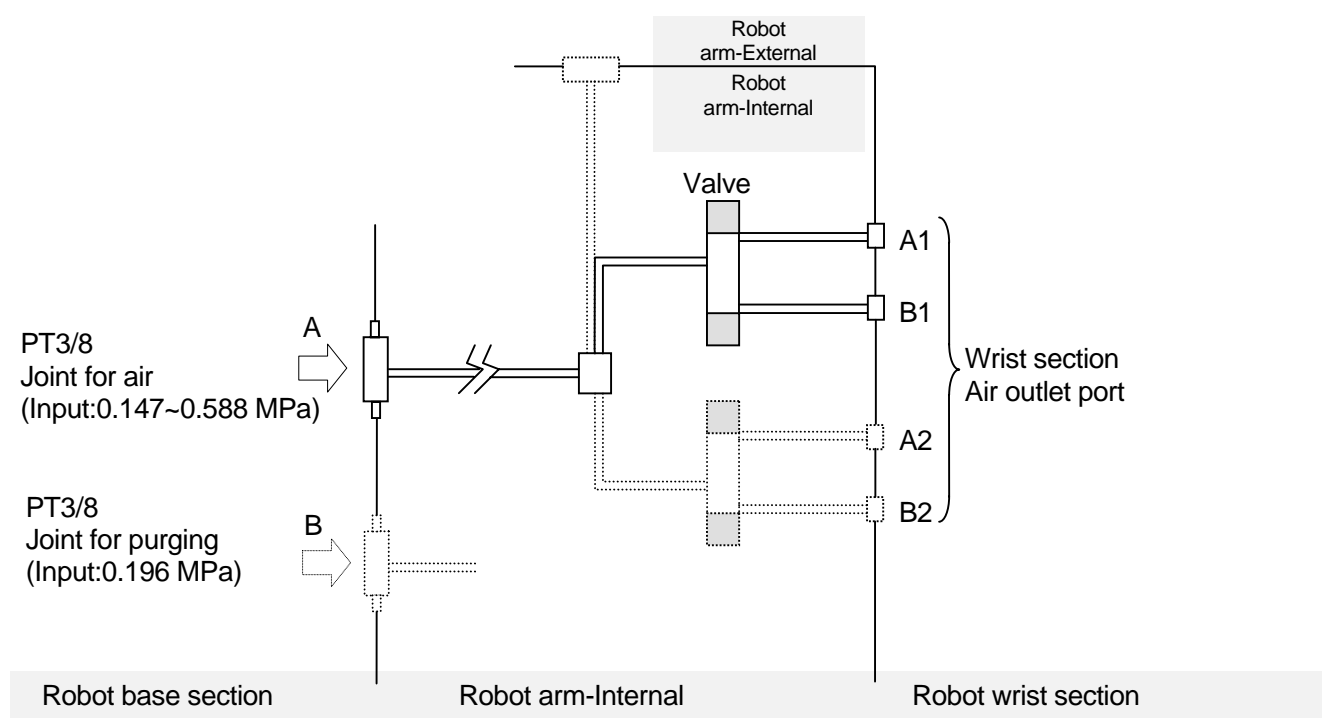

Optional equipment is shown by the dotted line (.....).

The built-in valves are specified as follows:

Standard	Double Solenoid		1 unit
Option	Double Solenoid		2 units
	Single solenoid		1 unit
	Single solenoid		2 units
	Double Solenoid	1 unit +	Single Solenoid 1 unit

Double Solenoid specification: CV value = 0.2 and 2-position

[NOTE]

Valves that do not meet the above specifications cannot be installed in the arm. Please contact KHI for information on air system specifications if such valves are used.

FS10X, FS20X, FS30N, FS30L, FS45C, FS45N, FD50N, FS60L

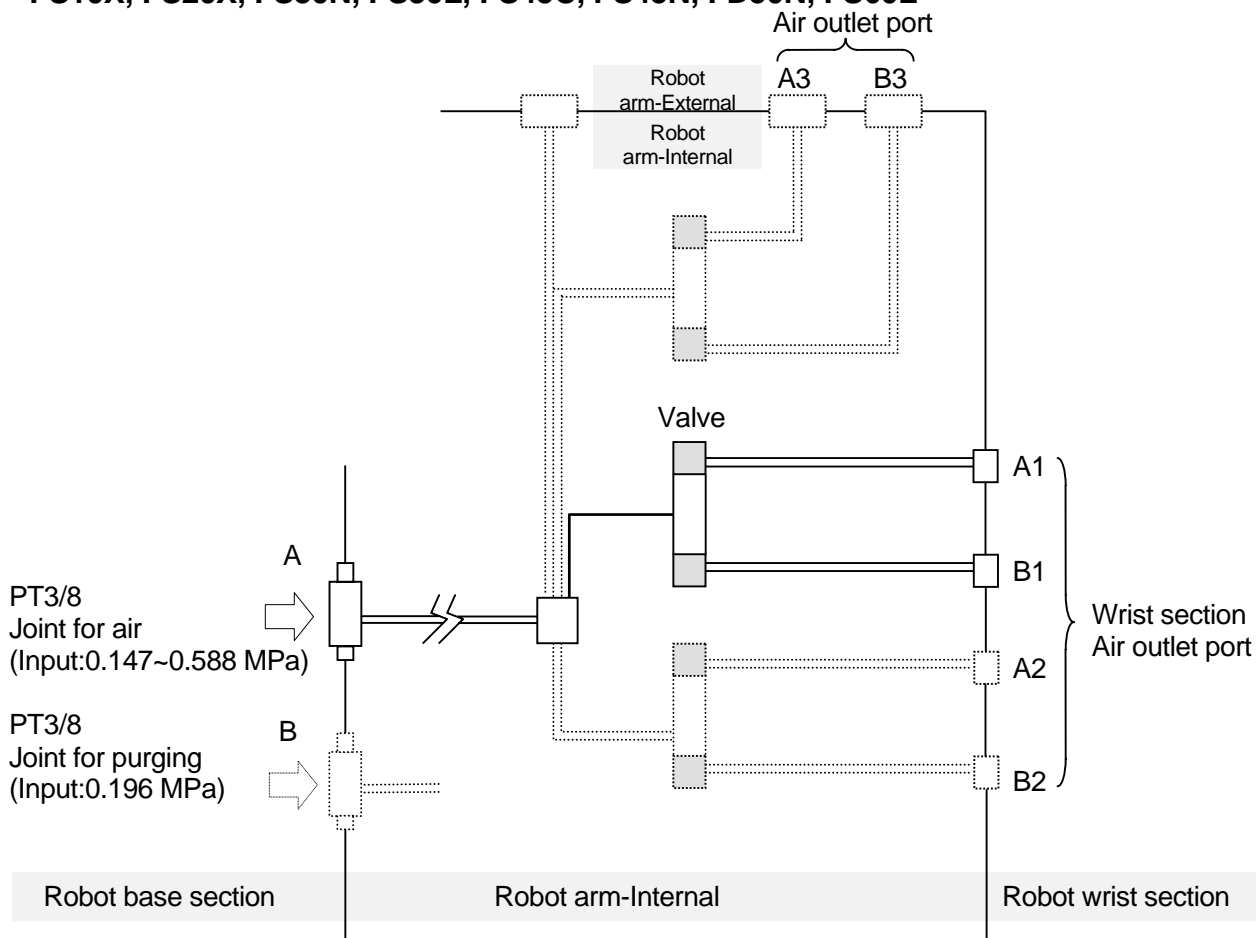

Optional equipment is shown by the dotted line (.....).

The built-in valves are specified as follows:

Standard	Double Solenoid		1 unit	
Option	Double Solenoid		2 units	
	Double Solenoid		3 units	
	Single Solenoid		1 unit	
	Single Solenoid		2 units	
	Single Solenoid		3 units	
	Double Solenoid	1 unit +	Single Solenoid	1 unit
	Double Solenoid	1 unit +	Single Solenoid	2 units
	Double Solenoid	2 units +	Single Solenoid	1 unit

Double Solenoid specification: CV value = 0.6 and 2-position.

[NOTE]

Valves that do not meet the above specifications cannot be installed in the arm. Please contact KHI for information on air system specifications if such valves are used.

FC06N, FC06L, FC10N, FC10L, FC20N

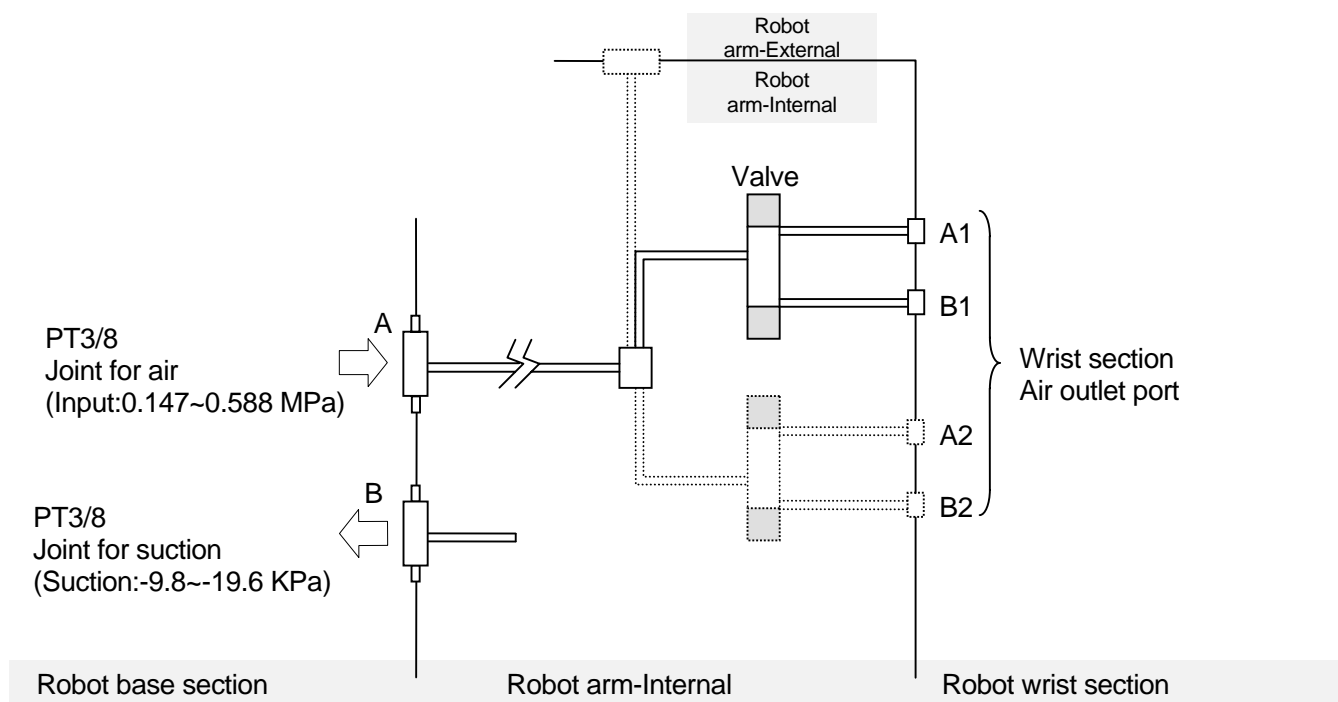

Optional equipment is shown by the dotted line (.....).

The built-in valves are specified as follows:

Standard	Double Solenoid	1 unit
Option	Double Solenoid	2 units
	Single Solenoid	1 unit
	Single Solenoid	2 units
	Double Solenoid 1 unit + Single Solenoid 1 unit	

Double Solenoid specification: CV value = 0.2 and 2-position.

[NOTE]

Valves that do not meet the above specifications cannot be installed in the arm. Please contact KHI for information on air system specifications if such valves are used.

FC30N, FC30L, FC45N

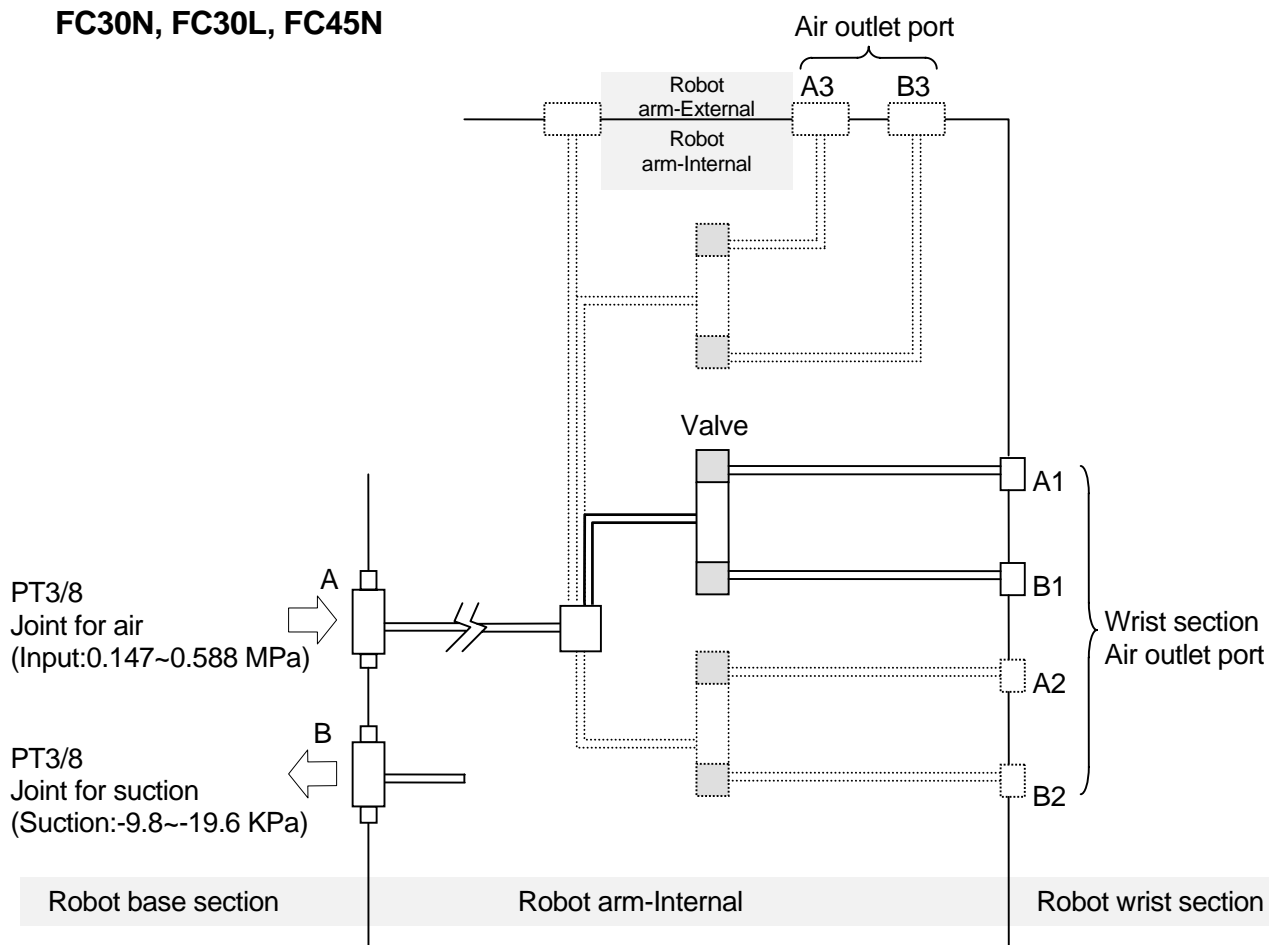

Optional equipment is shown by the dotted line (.....).

The built-in valves are specified as follows:

Standard	Double Solenoid	1 unit	
Option	Double Solenoid	2 units	
	Double Solenoid	3 units	
	Single Solenoid	1 unit	
	Single Solenoid	2 units	
	Single Solenoid	3 units	
	Double Solenoid	1 unit + Single Solenoid	1 unit
	Double Solenoid	1 unit + Single Solenoid	2 units
	Double Solenoid	2 units + Single Solenoid	1 unit

The Double Solenoid specification is: CV value = 0.6 and 2-position.

[NOTE]

Valves that do not meet the above specifications cannot be installed in the arm. Please contact KHI for information on air system specifications if such valves are used.

FC60L

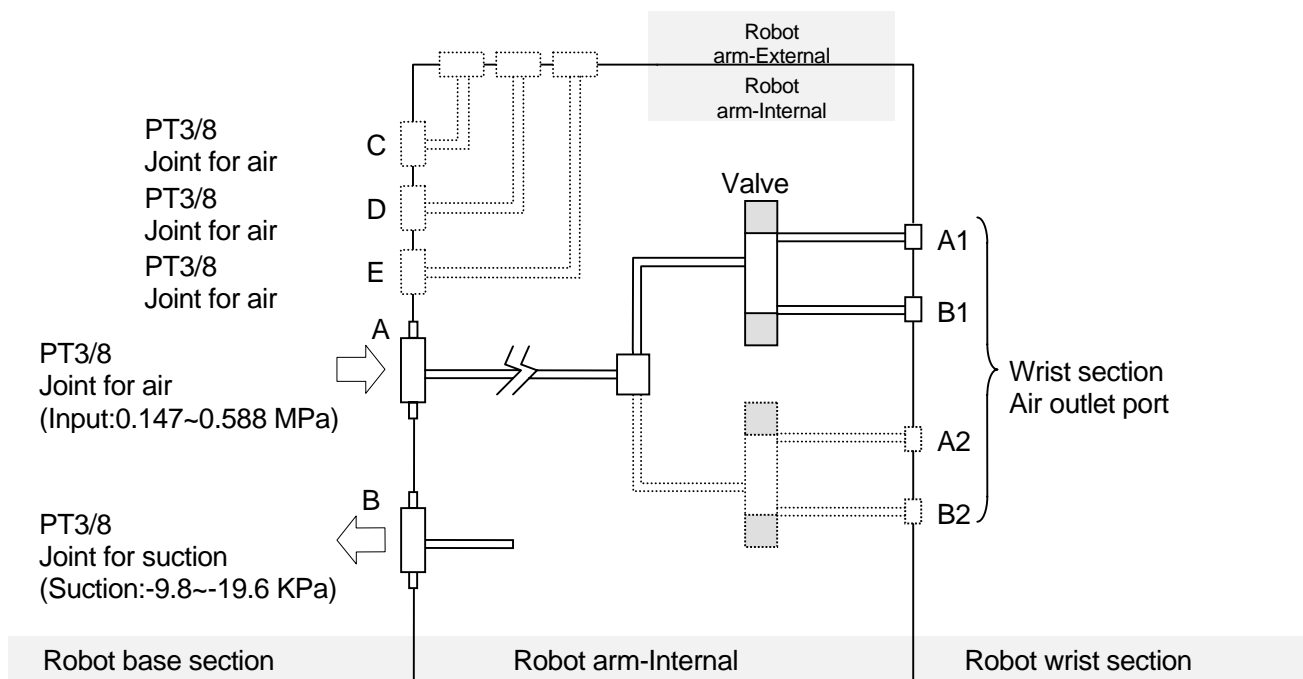

Optional equipment is shown by the dotted line (.....).

The built-in valves are specified as follows:

Standard	Double Solenoid	1 unit
Option	Double Solenoid	2 units
	Single Solenoid	1 unit
	Single Solenoid	2 units
	Double Solenoid 1 unit + Single Solenoid 1 unit	

Double Solenoid specification: CV value = 0.6 and 2-position.

[NOTE]

Valves that do not meet the above specifications cannot be installed in the arm. Please contact KHI for information on air system specifications if such valves are used.

9.2 AIR SUPPLY TO THE ROBOT ARM

- FS06N, FS06L, FC06N, FC06L, FS10C, FS10N, FS10E, FC10N

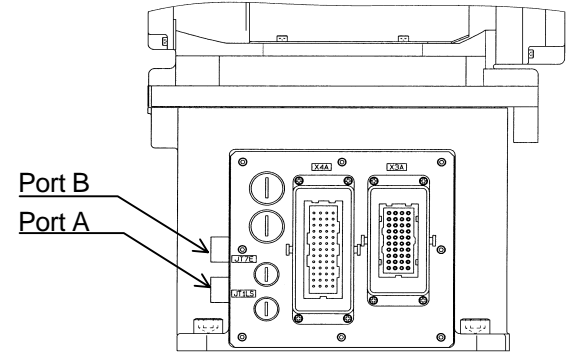

- FS10L, FC10L, FS20C, FS20N, FC20N

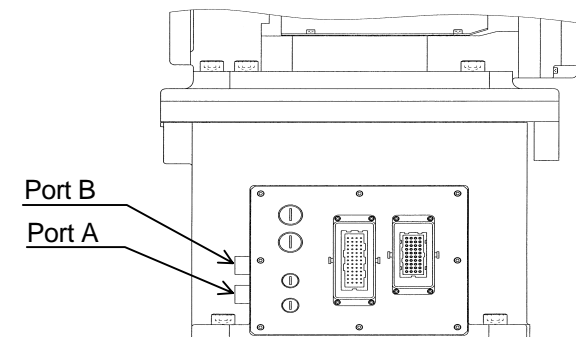

- FS10X, FS20X, FS30N, FS30L, FC30N, FC30L, FS45C, FS45N, FC45N, FD50N, FS60L

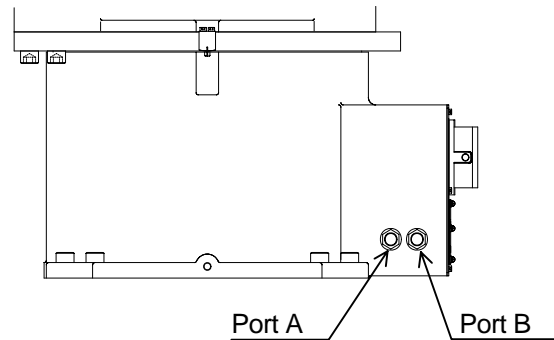
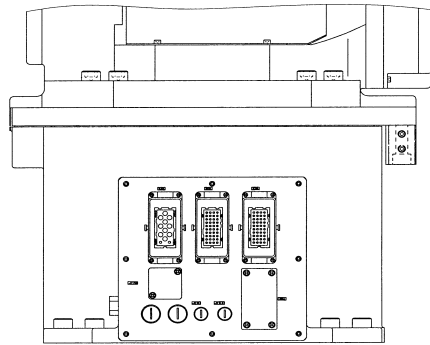

- FC60L

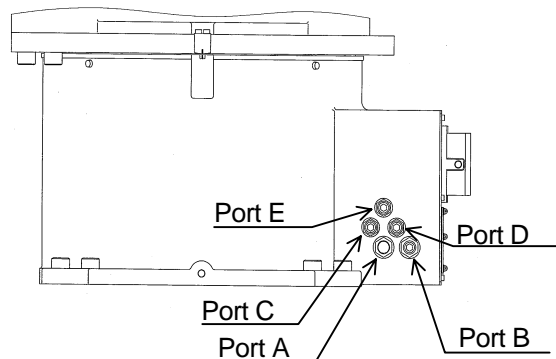
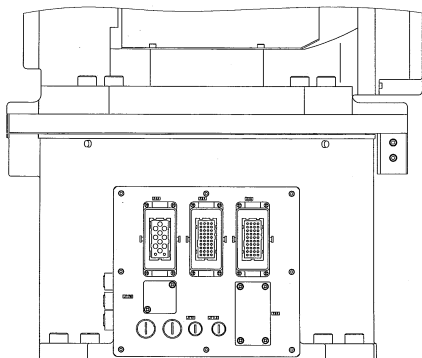

- As shown on the left and below, the air connection port is provided in the base section of robot arm.

CAUTION
Supply input pressure; 0.147~0.588 MPa to the Port A (PT3/8 Joint)

- For the air purge specification, Port B is provided with PT3/8 joint in the same way as Port A.

CAUTION
For air purge specification, supply clean dry air with input pressure of 0.196 MPa.

- For FC series, conduct purging from Port B.

CAUTION
For FC series, apply input pressure of -9.8 ~ -19.6 KPa.

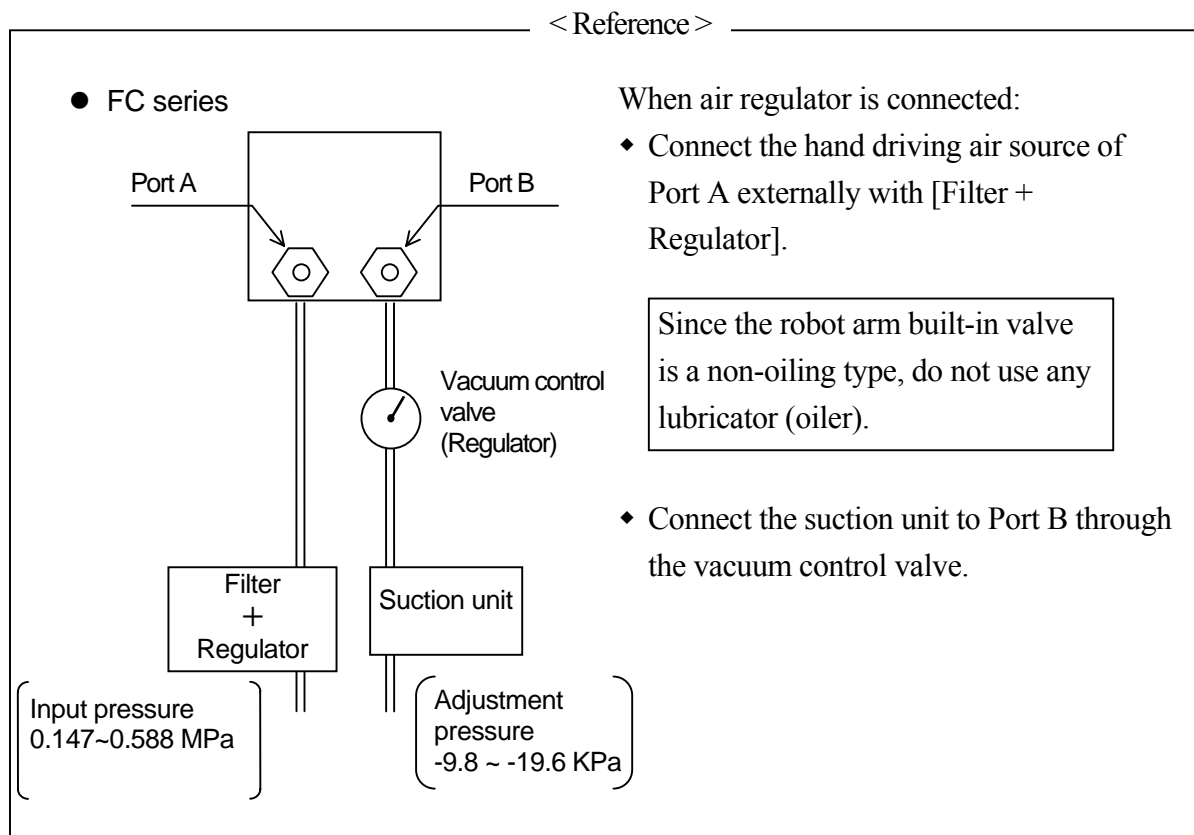
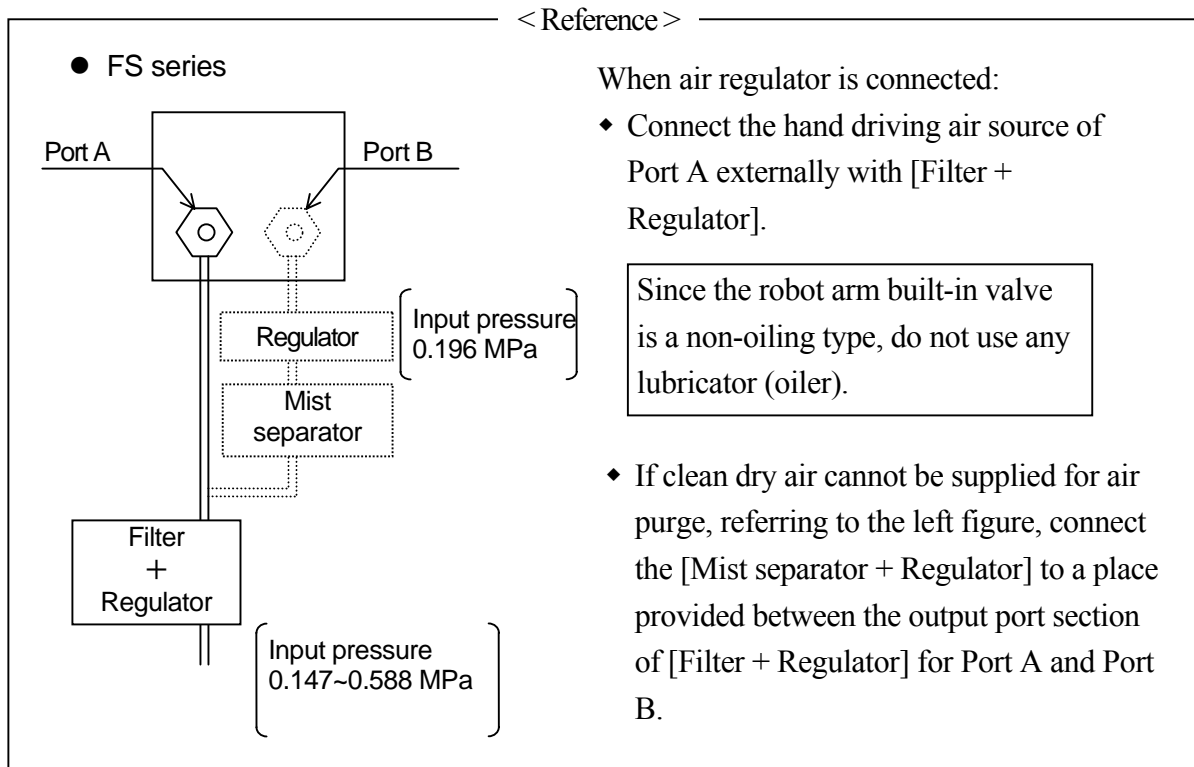

9.3 CONNECTION OF AIR OUTLET PORT IN THE WRIST SECTION WITH THE HAND

As shown in the figure below, air outlet ports are provided in the wrist section. The outlet ports are PT1/8 Joints.

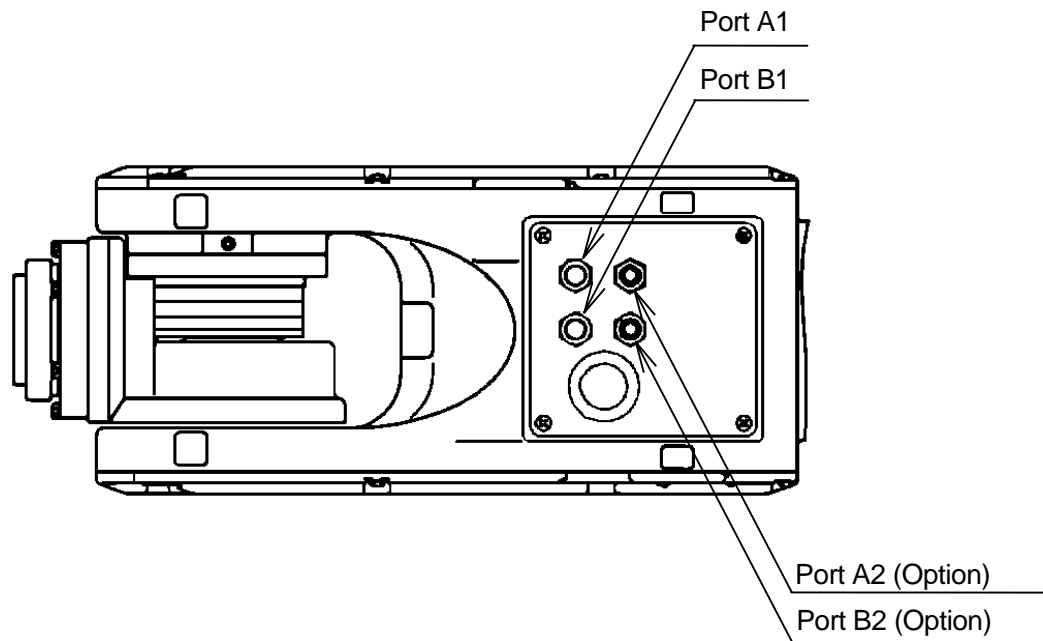

CAUTION

When mounting the joint, ensure that the joints for the air outlet ports are not turned. If the joints turn, the internal tube may bend or break causing the air to be trapped.

KAWASAKI ROBOT F Series (C0**)
INSTALLATION AND CONNECTION

May 2002 : 1st Edition
September 2006 : 4th Edition

Publication : KAWASAKI HEAVY INDUSTRIES, LTD.

90202-1062DED